

DOMINATOR TREX 500X Top Combo INSTRUCTION MANUAL

使用說明書

RH50E22XT

ALIGN



洗練
千錘百鍊 · 犀利登場

Contents	
1	INTRODUCTION 前言
1~2	SAFETY NOTES 安全注意事項
3	EQUIPMENT REQUIRED FOR ASSEMBLY 自備設備
3	PACKAGE ILLUSTRATION 包裝說明
4	MODEL STANDARD EQUIPMENT DIFFERENCE 標準配備版本說明
5	SAFETY CHECK BEFORE FLYING 飛行前安全檢查重要事項
6~18	ASSEMBLY SECTION 組裝說明
19	EQUIPMENT INSTALLATION 各項設備配置圖
20	BATTERY INSTALLATION ILLUSTRATION 電池安裝示意圖
20	CANOPY ASSEMBLY 機頭罩安裝
21	ELECTRIC EQUIPMENT ILLUSTRATION 電子設備建議配置圖示
21~22	MICROBEAST PLUS FLYBARLESS MANUAL 無平衡翼系統使用說明
23	SERVO SETTING AND ADJUSTMENT 伺服器設定調整
23	ADJUSTMENTS FOR GYRO AND TAIL NEUTRAL SETTING 陀螺儀與尾翼中立點設定調整
24	PITCH AND THROTTLE SETTING 主旋翼螺距與油門設定
25	POWER COLLOCATION REFERENCE 原裝動力數據參考表
25~28	RCE-BL80A BRUSHLESS SPEED CONTROLLER INSTRUCTION MANUAL 無刷调速器使用說明
27~28	FLIGHT ADJUSTMENT AND SETTING 飛行動作調整與設定
30	TROUBLESHOOTING 飛行中狀況排除



BEASTX

MICROBEAST PLUS

6-AXIS MEMS SENSOR SYSTEM FOR RC-MODELS

Thank you for purchasing Align products. Please read the manual carefully before installing and be sure to retain the manual for future reference. All pictures shown are for illustration purpose only. Actual product may vary due to product enhancement. Specifications, contents of parts and availability are subject to change, ALIGN RC is not responsible for inadvertent errors in this publications.

承蒙閣下選用亞拓遙控世界系列產品，謹表謝意。使用前，請務必詳閱本說明書，相信一定能夠給您帶來相當大的幫助，也請您妥善保管這本說明書，以做為日後參考。本公司將不對此印刷物之異動負責，也無法主動通知消費者任何更新或異動。所有圖片僅用於展示目的。產品可能因改良而有些不同。本說明書內記載的材質、規格或零件包裝之內容物如有異動，請依亞拓官網公告為主。

Thank you for buying ALIGN Products. The T-REX 500X Dominator Helicopter is designed as an easy to use, full featured Helicopter R/C model capable of all forms of rotary flight. Please read the manual carefully before assembling the model, and follow all precautions and recommendations located within the manual. Be sure to retain the manual for future reference, routine maintenance, and tuning. The T-REX 500X Dominator is a new product developed by ALIGN. It features the best design available on the R/C helicopters market to date, providing flying stability for beginners, full aerobatic capability for advanced fliers, and unsurpassed reliability for customer support.

感謝您選購亞拓產品，為了讓您容易方便的使用 T-REX 500X Dominator 直昇機，請您詳細的閱讀完這本說明書之後再進行組裝以及操作這台直昇機，同時請您妥善的保存這本說明書，作為日後進行調整以及維修的參考。T-REX 500X Dominator 是由亞拓自行研發的新產品，不論是需求飛行穩定性的初學者或是追求性能的飛行愛好者，T-REX 500X Dominator 將是您最佳的選擇。

WARNING LABEL LEGEND 標誌代表涵義

	Do not attempt under any circumstances. 在任何禁止的環境下，請勿嘗試操作。
	Mishandling due to failure to follow these instructions may result in damage or injury. 因為疏忽這些操作說明，而使用錯誤可能造成財產損失或嚴重傷害。
	Mishandling due to failure to follow these instructions may result in danger. 因為疏忽這些操作說明，而使用錯誤可能造成危險。

IMPORTANT NOTES 重要聲明

R/C helicopters, including the T-REX 500X Dominator are not toys. R/C helicopter utilize various high-tech products and Technologies to provide superior performance. Improper use of this product can result in serious injury or even death. Please read this manual carefully before using and make sure to be conscious of your own personal safety and the safety of others and your environment when operating all ALIGN products. Manufacturer and seller assume no liability for the operation or the use of this product. Intended for use only by adults with experience flying remote control helicopters at a legal flying field. After the sale of this product we cannot maintain any control over its operation or usage.

As the user of this product, you are solely responsible for operating it in a manner that does not endanger yourself and others or result in damage to the product or the property of others.

T-REX 500X Dominator 遙控直昇機並非玩具，它是結合了許多高科技產品所設計出來的休閒用品，所以商品的使用不當或不熟悉都可能會造成嚴重傷害甚至死亡，使用之前請務必詳讀本說明書，勿輕忽並注意自身安全。注意！任何遙控直昇機的使用，製造商和經銷商是無法對使用者於零件使用的損耗異常或組裝不當所發生之意外負任何責任，本產品是提供給有操作過模型直昇機經驗的成人或有相當技術的人員在旁指導於當地合法遙控飛行場飛行，以確保安全無虞下操作使用，產品售出後本公司將不負任何操作和使用控制上的任何性能與安全責任。

做為本產品的使用者，您，是唯一對於您自己操作的環境及行為負全部的責任之人。

We recommend that you obtain the assistance of an experienced pilot before attempting to fly our products for the first time. A local expert is the best way to properly assemble, setup, and fly your model for the first time. T-REX 500X Dominator requires a certain degree of skill to operate, and is a consumer item. Any damage or dissatisfaction as a result of accidents or modifications are not covered by any warranty and cannot be returned for repair or replacement. Please contact our distributors for free technical consultation and parts at discounted rates when you experience problems during operation or maintenance.

As Align Corporation Limited has no control over use, setup, final assembly, modification or misuse, no liability shall be assumed nor accepted for any resulting damage or injury. By the act of use, setup or assembly, the user accepts all resulting liability.

模型商品屬於需高操作技術且為消耗性之商品，如經拆裝使用後，會造成不等情況零件損耗，任何使用情況所造成商品不良或不滿意，將無法於保固條件內更換新品或退貨，如遇有使用操作維修問題，本公司全省分公司或代理商將提供技術指導、特價零件供應服務。對使用者的不當使用、設定、組裝、修改、或操作不良所造成的破損或傷害，本公司無法控制及負責。任何使用、設定、組裝、修改、或操作不良所造成的破損、意外或傷害，使用者應承擔全部責任。

SAFETY NOTES

安全注意事項



- Fly only in safe areas, away from other people. Do not operate R/C aircraft within the vicinity of homes or crowds of people. R/C aircraft are prone to accidents, failures, and crashes due to a variety of reasons including, lack of maintenance, pilot error, and radio interference. Pilots are responsible for their actions and damage or injury occurring during the operation or as a result of R/C aircraft models.
- Prior to every flight, carefully check rotorhead spindle shaft screws and tail blade grip screws, linkage balls and screws, ensure they are firmly secured.
- 遙控模型飛機、直昇機屬高危險性商品，飛行時務必遠離人群，人為組裝不當或機件損壞、電子控制設備不良，以及操控上的不熟悉，都有可能導致飛行失控損傷等不可預期的意外，請飛行者務必注意飛行安全，並需了解自負疏忽所造成任何意外之責任。
- 每趟飛行前須仔細檢查，主旋翼夾座橫軸螺絲、尾旋翼夾座螺絲，以及機身各部位球頭、螺絲，確實上膠鎖緊才能升空飛行。



LOCATE AN APPROPRIATE LOCATION 遠離障礙物及人群

R/C helicopters fly at high speed, thus posing a certain degree of potential danger. Choose a legal flying field consisting of flat, smooth ground without obstacles. Do not fly near buildings, high voltage cables, or trees to ensure the safety of yourself, others and your model. For the first practice, please choose a legal flying field. Do not fly your model in inclement weather, such as rain, wind, snow or darkness.

直昇機飛行時具有一定的速度，相對的也潛在著危險性，場地的選擇也相對的重要，請遵守當地法規到合法遙控飛行場地飛行。務必選擇在空曠合法專屬飛行場地，並必須注意周遭是否有人、高樓、建築物、高壓電線、樹木等等，避免操作的不當造成自己與他人財產的損壞。請勿在下雨、打雷等惡劣氣候下操作，以確保本身及機體的安全。



NOTE ON LITHIUM POLYMER BATTERIES 鋰聚電池注意事項

Lithium Polymer batteries are significantly more volatile than alkaline or Ni-Cd/Ni-MH batteries used in RC applications. All manufacturer's instructions and warnings must be followed closely. Mishandling of Li-Po batteries can result in fire. Always follow the manufacturer's instructions when disposing of Lithium Polymer batteries.

鋰聚電池跟一般在RC使用的鹼性電池、鎳鎘電池、鎳氫電池比較起來是相對危險的。請嚴格遵守鋰聚電池說明書之使用注意事項。不恰當使用鋰聚電池，可能造成火災並危及生命財產安全，切勿大意！

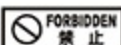
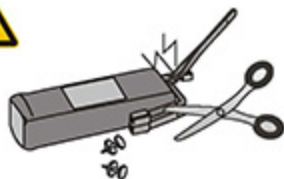

PREVENT MOISTURE 遠離潮濕環境

R/C models are composed of many precision electrical components. It is critical to keep the model and associated equipment away from moisture and other contaminants. The introduction or exposure to water or moisture in any form can cause the model to malfunction resulting in loss of use, or a crash. Do not operate or expose to rain or moisture.

直昇機內部也是由許多精密的電子零組件組成，所以必須絕對的防止潮濕或水氣，避免在浴室或雨天時使用，防止水氣進入機身內部而導致機件及電子零件故障而引發不可預期的意外！

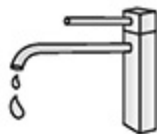

PROPER OPERATION 勿不當使用本產品

Please use the replacement of parts on the manual to ensure the safety of instructors. This product is for R/C model, so do not use for other purpose.

請勿自行改造加工，任何的升級改裝或維修，請使用亞拓產品目錄中的零件，以確保結構的安全。請確認於產品限界內操作，請勿過載使用，並勿用於安全、法令外其它非法用途。



OBTAIN THE ASSISTANCE OF AN EXPERIENCED PILOT 避免獨自操控

Before turning on your model and transmitter, check to make sure no one else is operating on the same frequency. Frequency interference can cause your model, or other models to crash. The guidance provided by an experienced pilot will be invaluable for the assembly, tuning, trimming, and actual first flight or unforeseen danger may happen. (Recommend you to practice with computer-based flight simulator.)

至飛行場飛行前，需確認是否有相同頻率的同好正進行飛行，因為開啓相同頻率的發射器將導致自己與他人立即干擾等意外危險。遙控飛機操控技巧在學習初期有著一定的難度，要盡量避免獨自操作飛行，需有經驗的人士在旁指導，才可以操控飛行，否則將可能造成不可預期的意外發生。(動線電腦模擬器及老手指導是入門必要的選擇)



SAFE OPERATION 安全操作

Do not attempt to grab or make contact with the helicopter while the main blades are in motion and keep your eyes away from the helicopter. During take-off, landing, and flight, be sure to keep the helicopter away from all obstacles. Operators must stand at least 10 meters away from the helicopter to avoid injury caused by loose parts due to improper assembly or any unforeseen dangers. Operate this unit within your ability. Do not fly under tired condition and improper operation may cause in danger. Never take your eyes off the model or leave it unattended while it is turned on. Immediately turn off the model and transmitter when you have landed the model.

嚴禁用手抓取運行中的直昇機，並禁止將直昇機對著眼睛，當主旋翼轉動後，或起飛/試飛時，務必遠離障礙物，站立位置必需距離10公尺以上，避免因人為組裝不當造成零件脫落，而引發不可預期的財物及人員損傷。請於自己能力內及需要一定技術範圍內操作這台直昇機，過於疲勞、精神不佳或不當操作，意外發生風險將可能會提高。不可在視線範圍外進行，降落後也請馬上關閉直昇機和遙控器電源。



ALWAYS BE AWARE OF THE ROTATING BLADES 遠離運轉中零件

During the operation of the helicopter, the main rotor and tail rotor will be spinning at a high rate of speed. The blades are capable of inflicting serious bodily injury and damage to the environment. Be conscious of your actions, and careful to keep your face, eyes, hands, and loose clothing away from the blades. Always fly the model a safe distance from yourself and others, as well as surrounding objects.

直昇機主旋翼與尾旋翼運轉時會以高轉速下進行，在高轉速下的旋翼會造成自己與他人在身體上或環境上的嚴重損傷，請勿觸摸運轉中的主旋翼與尾旋翼，並保持安全距離以避免造成危險及損壞。



KEEP AWAY FROM HEAT 遠離熱源

R/C models are made of various forms of plastic. Plastic is very susceptible to damage or deformation due to extreme heat and cold climate. Make sure not to store the model near any source of heat such as an oven, or heater. It is best to store the model indoors, in a climate-controlled, room temperature environment.









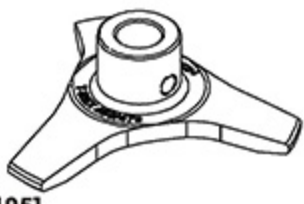

遙控飛機多半是以 PA 纖維或聚乙烯、電子商品為主要材質，因此要盡量遠離熱源、日曬，以避免因高溫而變形甚至熔毀損壞的可能。





RADIO TRANSMITTER AND ELECTRONIC EQUIPMENT REQUIRED FOR ASSEMBLY 自備遙控及電子設備

 <p>Transmitter (6-channel or more, helicopter system) 發射器 (六動以上直昇機模式遙控器)</p>	 <p>Receiver (6-channel or more) 接收器 (六動以上)</p> <p>or</p> <p>Remote Receiver 衛星天線</p>
 <p>22.2V 6S 2,600~3,300mAh LI-Po Battery x 1 22.2V 6S 2,600~3,300mAh LI-Po 電池 x 1</p>	 <p>RCC-300 Intelligent Battery Charger RCC-300 智慧型充電器</p>

ADDITIONAL TOOLS REQUIRED FOR ASSEMBLY 自備工具

 <p>[H50195] Swashplate Leveler 十字盤校正器</p>	 <p>[HET80001] AP800 Digital Pitch Gauge AP800 數位螺距規</p>	 <p>[HETMT901] Multi-function Tester 多功能檢測計</p>					
 <p>Phillips Screw Driver 十字螺絲起子 Φ 3.0 / Φ 1.8mm</p>	 <p>Cutter Knife 刀子</p>	 <p>Hexagon Screw Driver 六角螺絲起子 3mm/2.5mm/ 2mm/1.5mm</p>	 <p>Needle Nose Pliers 尖嘴鉗</p>	 <p>Oil 潤滑油</p>	 <p>CA Glue 瞬間膠</p>	 <p>Grease 潤滑油</p>	 <p>Anaerobic Retainer (R48) 缺氧膠 (R48)</p>

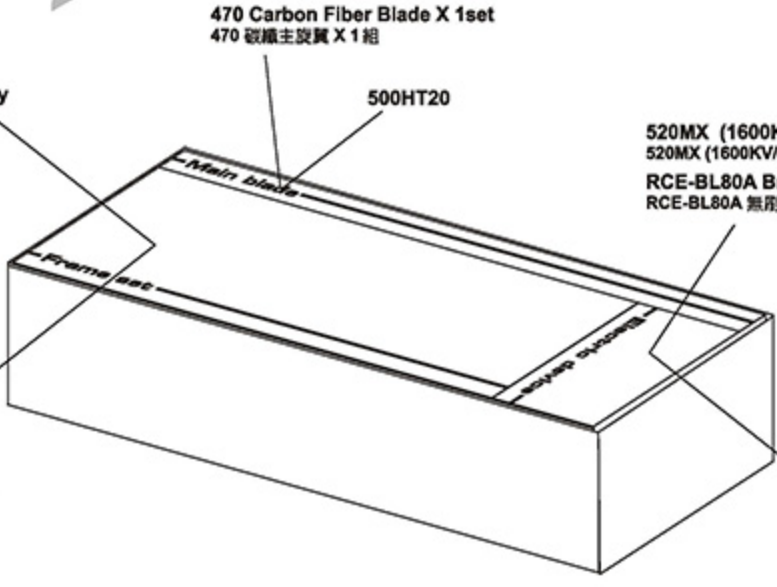
PACKAGE ILLUSTRATION 包裝說明













 <p>470 Carbon Fiber Blade X 1set 470 碳纖維旋翼 X 1 組</p> <p>500HT20</p> <p>520MX (1600KV/3527) Brushless Motor x 1 520MX (1600KV/3527) 無刷馬達 x 1</p> <p>RCE-BL80A Brushless ESC x 1 RCE-BL80A 無刷定速調速器 x 1</p> <p>DS530M High Voltage Brushless Servo x 3 DS530M 高壓無刷伺服器 x 3</p> <p>DS535M High Voltage Brushless Servo x 1 DS535M 高壓無刷伺服器 x 1</p> <p>500HC7 500HH18 500HB12 500HB11 500HB13 500HT18 500HT19 500HG3</p> <p>Canopy 機頭罩</p> <p>Main blade</p> <p>Prime use</p> <p>Electronic device</p>	<p>Quick Finder 零件快速購</p> 
---	--

There are many versions of T-REX 500X Dominator for your choice. The TOP Combo includes additional electronics and other equipment. The Instruction Manual will refer to the T-REX 500X Dominator TOP Combo. You may purchase any additional items referenced in the instruction manual or any spare parts for other 500X Dominator version by referring to more product information in this manual.

T-REX 500X Dominator 系列商品有多種版本可作為選擇，除標準配備會因您購買的商品版本而有些微不同，在組裝、設定上都是一致的，在此我們以TOP Combo作為操作範例，您也可依照書面上的商品資訊來增添其他選購商品。



T-REX 500X DOMINATOR TOP COMBO STANDARD EQUIPMENT T-REX 500X DOMINATOR TOP COMBO 標準配備 [RH50E22XT]

 <p>500HC7</p>	 <p>500HH18</p>	 <p>500HB12</p>	 <p>500HB11</p>	 <p>500HB13</p>
 <p>500HT18</p>	 <p>500HT19</p>	 <p>500HT20</p>	 <p>500HG3</p>	 <p>M3x3 Set Screw x2 M3 止洩螺絲 x2 Motor Pinion Helical Gear 12T x 1 馬達斜齒輪 12T x 1</p>
 <p>520MX (1600KV/3527) Brushless Motor x 1 520MX (1600KV/3527) 無刷馬達 x 1</p>	 <p>RCE-BL80A Brushless ESC x 1 RCE-BL80A 無刷定速調速器 x 1</p>	 <p>Microbeast PLUS Flybarless System x 1 無平衡翼系統 x 1</p>	 <p>DS530M Digital Servo x 3 DS530M 數位伺服器 x 3 DS535M Digital Servo x 1 DS535M 數位伺服器 x 1</p>	 <p>470 Carbon Fiber Blade X 1 470 碳纖主旋翼 X 1</p>

CAREFULLY INSPECT BEFORE REAL FLIGHT 請嚴格執行飛行前之檢查義務

- Before flying, please check to make sure no one else is operating on the same frequency for the safety.
 - Before flight, please check if the batteries of transmitter and receiver are enough for the flight.
 - Before turn on the transmitter, please check if the throttle stick is in the lowest position. IDLE switch is OFF.
 - When turn off the unit, please follow the power on/off procedure. Power ON- Please turn on the transmitter first, and then turn on receiver. Power OFF- Please turn off the receiver first and then turn off the transmitter. Improper procedure may cause out of control, so please to have this correct habit.
 - Before operation, check every movement is smooth and directions are correct. Carefully inspect servos for interference and broken gear.
 - Check for missing or loose screws and nuts. See if there is any cracked and incomplete assembly of parts. Carefully check main rotor blades and rotor holders. Broken and premature failures of parts possibly cause a dangerous situation.
 - Check all ball links to avoid excess play and replace as needed. Failure to do so will result in poor flight stability.
 - Check if the battery and power plug are fastened. Vibration and violent flight may cause the plug loose and result in out of control.
- 每次飛行前應先確認所使用的頻率是否會干擾他人，以確保您自身與他人的安全。
 - 每次飛行前確定您發射器與接收器電池的電量是在足夠飛行的狀態。
 - 開機前確認油门搖桿是否位於最低點，熄火降落開關，定速開關 (IDLE) 是否於關閉位置。
 - 關機時必須遵守電源開關機的程序，開機時應先開啟發射器後，再開啟接收器電源；關機時應先關閉接收器後，再關閉發射器電源。不正確的開關程序可能會造成失控的現象，影響自身與他人的安全，請養成正確的習慣。
 - 開機請先確定直昇機各個動作是否順暢，及方向是否正確，並檢查伺服器的動作是否有干涉或崩齒的情形，使用故障的伺服器將導致不可預期的危險。
 - 飛行前確認沒有缺少或鬆脫的螺絲與螺帽，確認沒有組裝不完整或損毀的零件，仔細檢查主旋翼是否有損壞，特別是接近主旋翼夾座的部位。損壞或組裝不完整的零件不僅影響飛行，更會造成不可預期的危險。注意：每次飛行前的安全檢查、保養、及更換損耗零件，請確實嚴格執行以確保安全。
 - 檢查所有的連桿頭是否有鬆脫的情形，過鬆的連桿頭應先更新，否則將造成直昇機無法操控的危險。
 - 確認電池及電源接頭是否固定牢靠，飛行中的震動或激烈的飛行，可能造成電源接頭鬆脫而造成失控的危險。

When you see the marks as below, please use relative glue or grease to ensure flying safety.
標有以下符號之組裝步驟，請配合上膠或上油，以確保鎖附零件使用之可靠度。



- CA : Apply small amount of CA Glue to fix.
瞬間膠：使用適量瞬間膠固定
- R48 : Apply small amount of Anaerobic Retainer to fix.
缺氧膠：使用適量缺氧膠固定
- T43 : Apply small amount of Thread Lock to fix.
螺絲膠：使用適量螺絲膠
- OIL : Add small amount of OIL.
潤滑油：添加適量潤滑油
- Grease : Add small amount of Grease.
潤滑油：添加適量潤滑油

When assembling ball links, make sure the "A" character faces outside.
各項塑膠製連桿頭扣接時，"A"字朝朝外。



Keep plastic parts away from heat.
塑膠件避免接近熱源。



CA Glue
瞬間膠



Anaerobic Retainer
缺氧膠



Thread Lock
螺絲膠



Grease
潤滑油



Oil
潤滑油

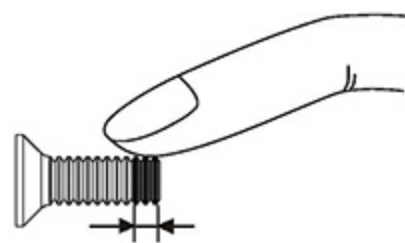

T43 Glue width : approx. 1mm
T43 上膠寬度約 1mm

1. Anaerobic Retainer (R48) is green penetrating threadlocker and is used to fix the metal tube before assembly at temperatures up to +180°C.
2. Thread Lock (T43) is blue low strength threadlocker and is applied to the small screw (threads) or metal parts before assembly to prevent loosening. Ensure to apply only a small amount and wipe surplus off. When disassembling, recommend to heat the metal joint about 15 Seconds.
3. Grease is kind of lubricant additive which is applied to the one-way bearings or thrust bearing.

Based on parts physical attributes, please apply small amount of the relative glue or grease accordingly to prevent any parts damage or loosening or unexpected danger happened.

1. 缺氧膠 (R48) 為綠色高強度快速固化的缺氧膠，適合於金屬管狀固定用，可耐高溫至 180°C。
2. 螺絲膠 (T43) 為藍色低強度螺絲膠，適合小型螺絲；使用於金屬內外徑或膠合螺絲時，請務必適量使用，必要時請用手去除多餘膠量，欲拆卸時可於金屬接合部位熱烤約 15 秒。
3. 潤滑油 (Grease) 為膏狀潤滑油，適用於單向軸承或止推軸承。

上述各類功能膠(油)請依零件屬性需求自行準備並斟酌其用量，以達到最佳組裝狀態，避免因使用不當造成零件損壞或不可預期的意外發生。

500HH18

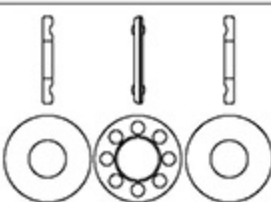

Thrust Bearing
止推軸承 (φ 5x φ 12x4mm) x 2



Washer
華司 (φ 9x φ 12x0.8mm) x 2



Bearing
軸承 (φ 6x φ 12x4mm) x 4



Socket Collar Screw
圓頭內六角軸套螺絲 (M3x6mm) x 4

Recessed Side of
Bearing Faces In.
軸承面凹開口朝內

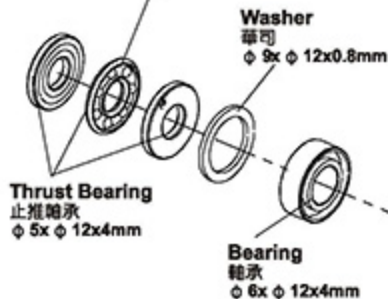

Thrust Bearing
止推軸承
φ 5x φ 12x4mm

Washer
華司
φ 9x φ 12x0.8mm

Bearing
軸承
φ 6x φ 12x4mm

Apply a small amount of T43 thread lock when fixing a metal part.
螺絲鎖附於金屬件請使用適量T43(螺絲膠)。



Original manufactory packages contains product already assembled, please confirm every screw is firmly secured with T43. Do not use T43 on any plastic part.

原裝零件出廠包裝如果是組裝品，請需再確認各螺絲是否鎖緊上膠。請注意T43不可塗在任何的塑膠材質上。



Thrust Bearing 止推軸承

Main Rotor Holder
主旋翼夾座

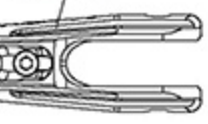

Apply Grease On
Thrust Bearing
止推軸承塗上潤滑油



"IN" Mark Faces Inside
"IN"字請朝內

Thin (Larger ID)
(內徑較大)

Thick (Smaller ID)
(內徑較小)

"OUT" Mark
Faces Out
"OUT"字請朝外

Main Rotor Holder
主旋翼夾座



Thrust bearing and washer for radial bearing are wear items; therefore, it is recommended to inspect after every 20 flights and replaced as necessary. For flights with high headspeed, the inspection interval should be reduced to ensure flight safety.

止推軸承及橫軸墊圈屬於飛行消耗品，建議每20趟定期檢查及更換。高主旋翼轉速飛行時，請縮短定期檢查之週數，以確保飛行安全。

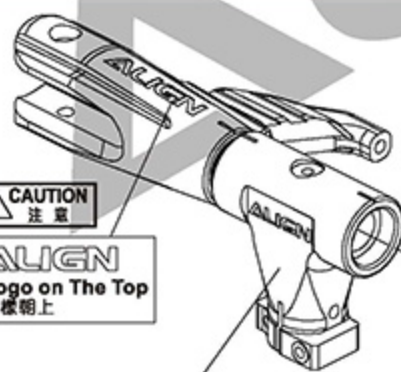

ALIGN
Logo on The Top
字樣朝上

Main Rotor Housing
主旋翼固定座

Feathering Shaft
橫軸
φ 5x φ 6x76.2mm

Apply Grease
塗上潤滑油

Damper Rubber
橫軸墊圈
φ 6x φ 11x4mm



ALIGN
Logo on The Top
字樣朝上

Feathering Shaft Sleeve
橫軸套管
φ 6x φ 8x26mm

Spindle
Bearing Spacer
橫軸套圈
φ 6.1x φ 10.5x1.5mm

Washer
華司
φ 3x φ 10x1mm

500HH18



Damper Rubber
橫軸墊圈 (φ 6x φ 11x4mm) x 2



Washer
橫軸華司 (φ 3x φ 10x1mm) x 2

Spindle Bearing Spacer
橫軸套圈 (φ 6.1x φ 10.5x1.5mm) x 2



Please apply a small amount of T43 when tightening the feathering shaft socket screws and make sure to tighten firmly, but not over tighten. Suggest using a torque wrench or torque lock when tightening screws. Torque value 7.0kg.cm

橫軸螺絲鎖附時常注意鎖附之緊度與使用適量的螺絲膠，建議搭配扭力扳手或扭力機鎖附螺絲，鎖定扭力值為7.0kg.cm。

Socket Screw
圓頭內六角螺絲
M3x10mm

500HH18

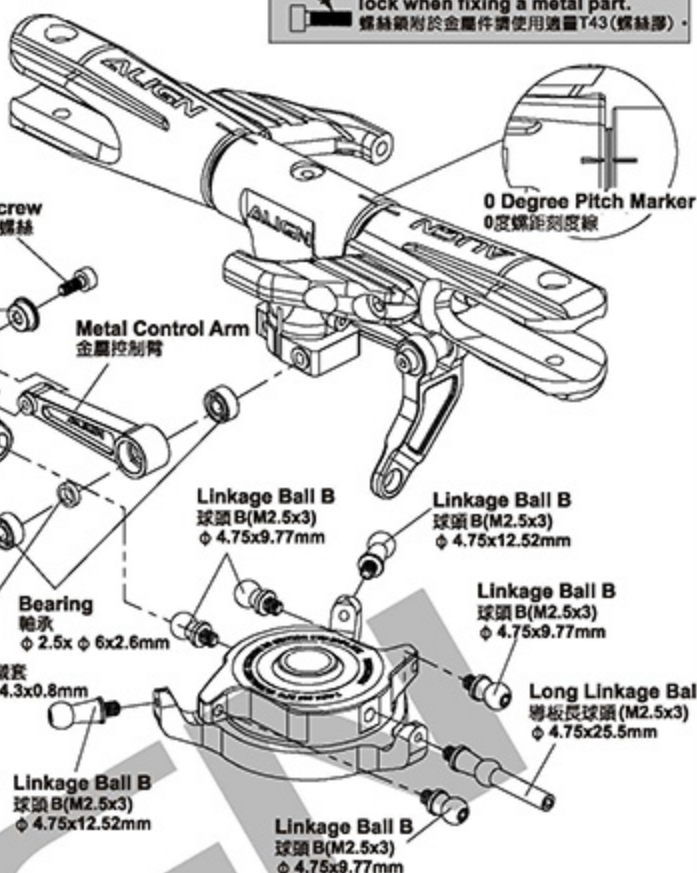
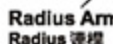
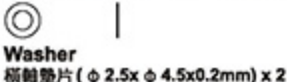
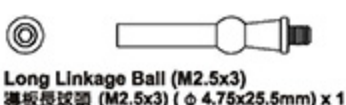

500HH18

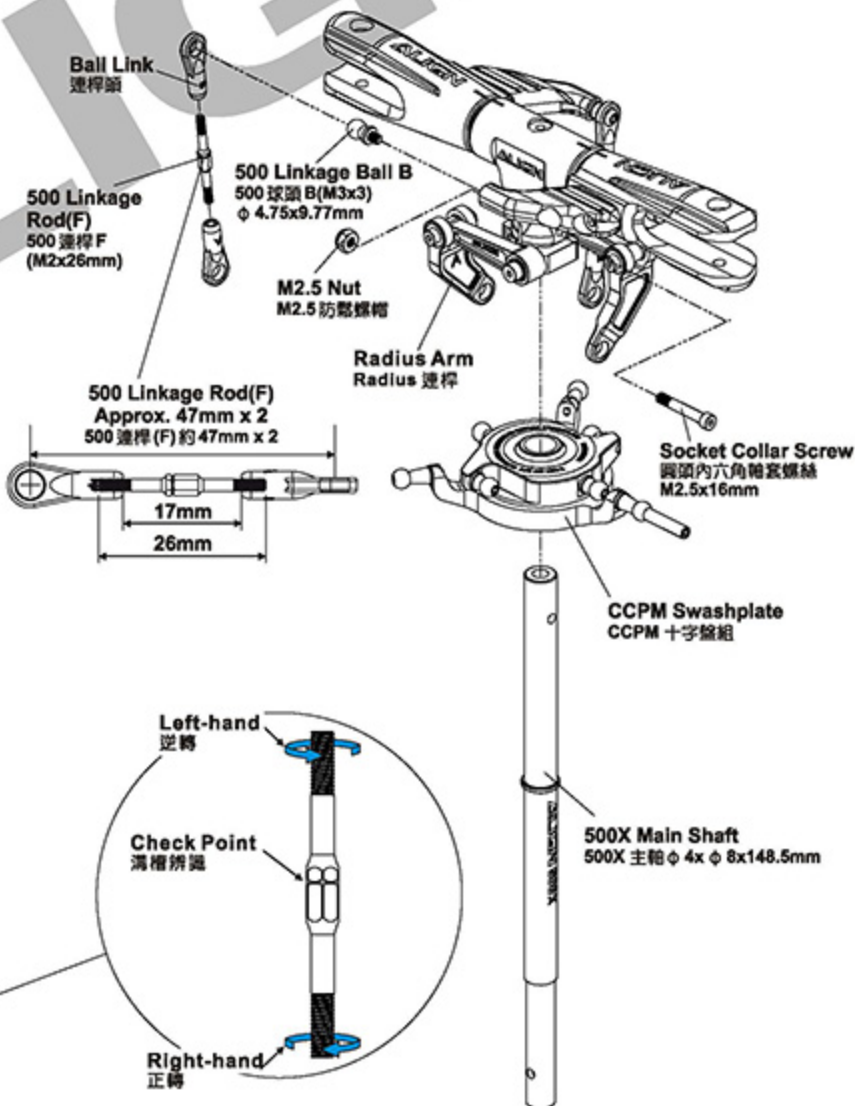

Original manufactory packages contains product already assembled, please confirm every screw is firmly secured with T43. Do not use T43 on any plastic part.

原裝零件出廠包裝如果是組裝品，請再確認各螺絲是否鎖緊上膠。請注意T43不可塗在任何的塑膠材質上。



Adjust the length of ball link, if during flight blade tracking is off.
若飛行中有雙槳情形，可適當調整連桿頭長短改善。



For installation, make sure the "Check Point" is closest to the swashplate, upward. Use a wrench grasp the center of hexagonal rod to adjust its suitable length, turn clockwise to decrease the length, or turn counter clockwise to increase the length.

組裝時請將連桿中間有溝槽辨識端朝上。請使用尖嘴鉗或扳手轉動連桿中間六角柱部位調整適當長度，順時針轉動為調短連桿長度；逆時針轉動則為調長連桿長度。

500HB12



Bearing
軸承 (φ8xφ16x5mm) x 2



Bearing
軸承 (φ7xφ11x3mm) x 1



M2.5 Specialty Washer
M2.5特殊華司 (φ2.6xφ6x2mm) x 12



Socket Screw
圓頭內六角螺絲 (M2.5x6mm) x 12



Socket Screw
圓頭內六角螺絲 (M2.5x8mm) x 2

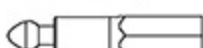

Front Canopy Mounting Bolt
前機頭罩固定柱 (M2.5x25.3mm) x 2



Socket Button Head Screw
半圓頭內六角螺絲 (M2.5x6mm) x 2

Carbon Main Frame(R)
碳纖維板(右)

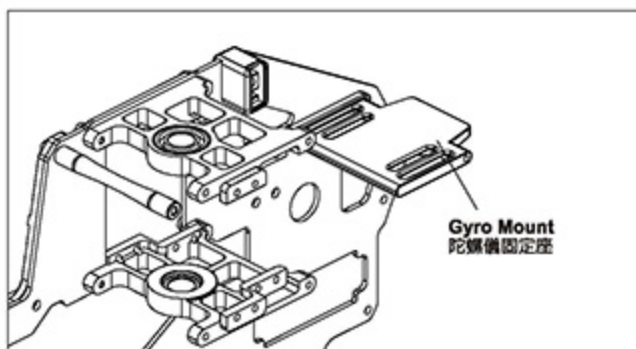

Gyro Mount
陀螺儀固定座

Apply a small amount of T43 thread lock when fixing a metal part.
螺絲鎖附於金屬件請使用適量T43(螺絲膠)。



Original manufactory packages contains product already assembled, please confirm every screw is firmly secured with T43. Do not use T43 on any plastic part.

原裝零件出廠包裝如果是組裝品，請再確認各螺絲是否鎖緊上膠。請注意T43不可塗在任何的塑膠材質上。

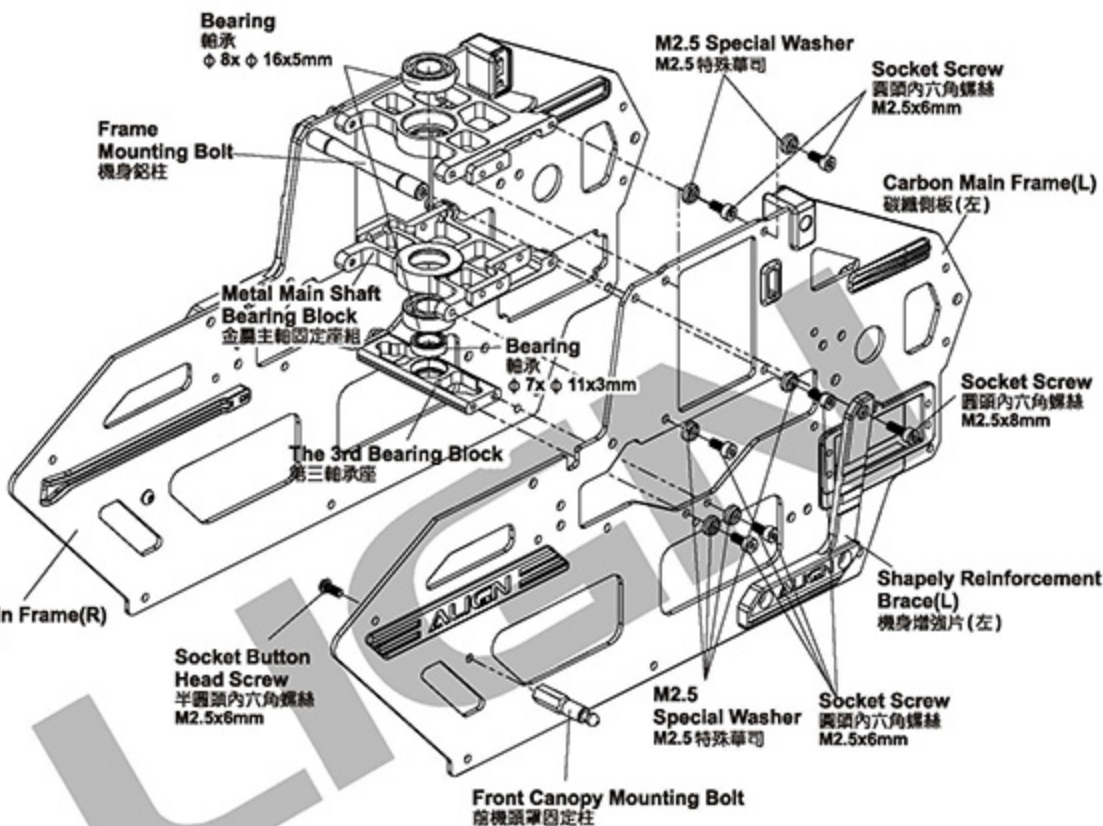

Bearing
軸承
φ8xφ16x5mm

Frame Mounting Bolt
機身鋁柱

Metal Main Shaft Bearing Block
金屬主軸固定座組

The 3rd Bearing Block
第三軸承座

Socket Button Head Screw
半圓頭內六角螺絲
M2.5x6mm

Front Canopy Mounting Bolt
前機頭罩固定柱

M2.5 Special Washer
M2.5特殊華司

Socket Screw
圓頭內六角螺絲
M2.5x6mm

Carbon Main Frame(L)
碳纖維板(左)

Socket Screw
圓頭內六角螺絲
M2.5x8mm

Shapely Reinforcement Brace(L)
機身增強片(左)

M2.5 Special Washer
M2.5特殊華司

Socket Screw
圓頭內六角螺絲
M2.5x6mm

500HB12



Socket Screw
圓頭內六角螺絲 (M2.5x4mm) x 2

500HG2A



Socket Screw
圓頭內六角螺絲 (M2.5x8mm) x 4



Washer
華司 (φ2.6xφ5.8x0.6mm) x 4

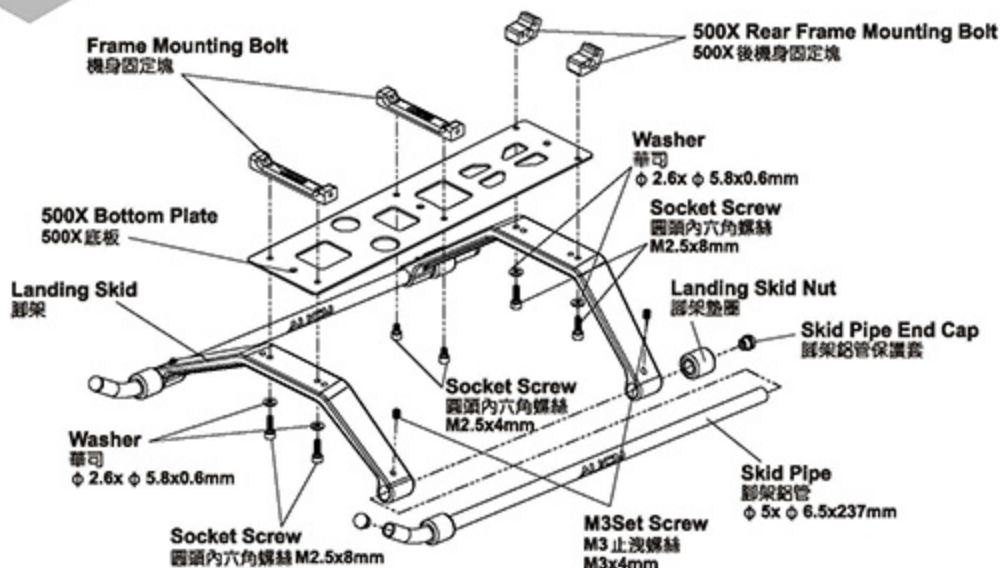

Frame Mounting Bolt
機身固定塊

500X Rear Frame Mounting Bolt
500X後機身固定塊

500X Bottom Plate
500X底板

Landing Skid
腳架

Washer
華司
φ2.6xφ5.8x0.6mm

Socket Screw
圓頭內六角螺絲
M2.5x8mm

Washer
華司
φ2.6xφ5.8x0.6mm

Socket Screw
圓頭內六角螺絲
M2.5x8mm

Landing Skid Nut
腳架墊圈

Skid Pipe End Cap
腳架鋁管保護套

Socket Screw
圓頭內六角螺絲
M2.5x4mm

Skid Pipe
腳架鋁管
φ5xφ6.5x237mm

M3Set Screw
M3止洩螺絲
M3x4mm

PROGRESSIVE LIGHTWEIGHT LANDING SKID

前衛新型前傾輕量化設計的腳架

Landing skid is tilted 5 degree forward which improves crashworthiness.

新型腳架質輕耐撞擊，為前傾5度俯衝設計。





Main frame assembly key point :

Do not fully tighten the screws on main frames. Insert the main shaft through the three bearings to check if the movement is smooth. The bottom bracket must be firmly level on table top, such as a glass surface; please keep the smooth movements on main shaft and level bottom bracket, then slowly tighten the screws. This assembly can help for power and flight performance.

機身側板組立重點：

側板螺絲先不完全鎖緊，放入主軸貫穿二顆軸承確認上下移動必需滑順，主體底板必須與水平桌面(玻璃平面)踏實緊貼；請保持主軸滑順與底板平行桌面後慢慢鎖緊螺絲。正確側板的組裝對動力與飛行性能有顯著幫助。

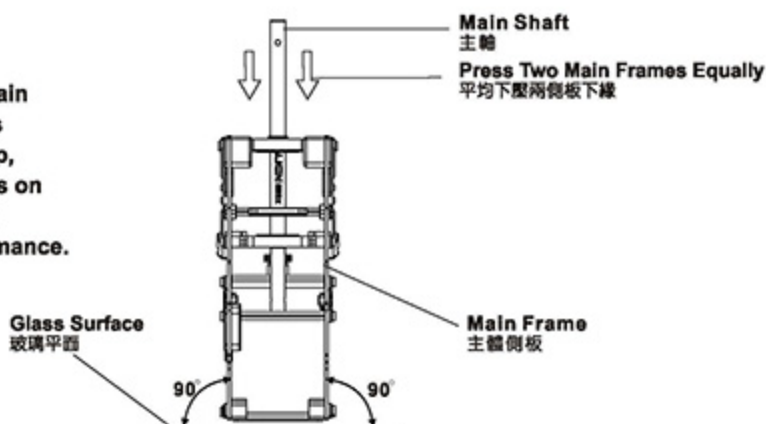

Apply a small amount of T43 thread lock when fixing a metal part.
螺絲鎖附於金屬件請使用適量T43(螺絲膠)。



Original manufactory packages contains product already assembled, please confirm every screw is firmly secured with T43. Do not use T43 on any plastic part.

原裝零件出廠包裝如果是組裝品，請需再確認各螺絲是否鎖緊上膠。請注意T43不可塗在任何的塑膠材質上。

Recommend sanding the marked position with a waterproof abrasive paper (#800-1000) as illustrated below to avoid the wires of electric parts being cut.

建議於下圖色塊標示處，可使用#800~1000水砂紙打磨，可防止電子設備電線被割破。



500HB12

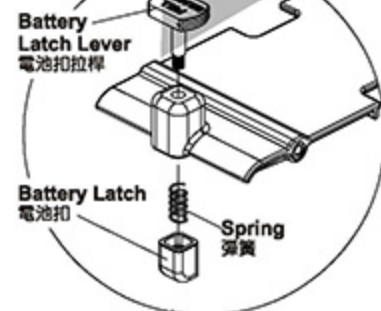

Battery Release Latch Installation Illustration
電池扣安裝示意圖

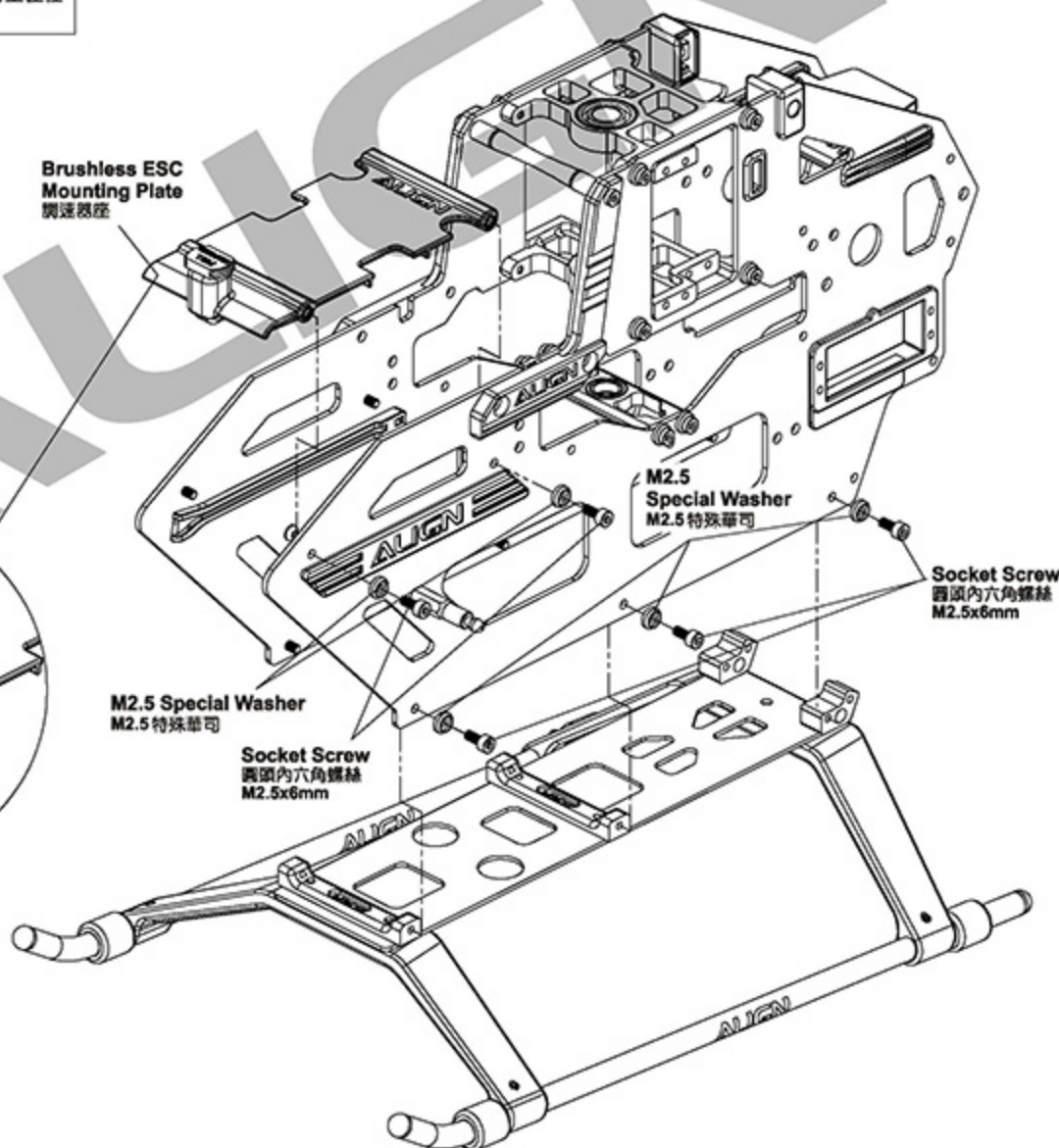

500HZ16



Socket Screw

圓頭內六角螺絲 (M2.5x8mm) x 8



Washer

華司 (φ 2.6x φ 5.8x0.6mm) x 8



Linkage Ball B(M2.5x3)

球頭 B(M2.5x3)(φ 4.75x12.52mm) x 2

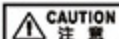

Please follow the manual instruction for servo washer and copper bush assembly. With the servo copper bush, the servo can be assembled properly to prevent screw over tightening or unbalanced force on screw.

伺服器墊圈與銅套須依照說明書指示安裝，銅套有定位防止螺絲鎖附不均與過度鎖附情況，所以安裝時不可漏裝銅套。



Apply a small amount of T43 thread lock when fixing a metal part.

螺絲鎖附於金屬件請使用適量T43(螺絲膠)。



Original manufactory packages contains product already assembled, please confirm every screw is firmly secured with T43. Do not use T43 on any plastic part.

原裝零件出廠包裝如果是組裝品，請需再確認各螺絲是否鎖緊上膠。請注意T43不可塗在任何的塑膠材質上。

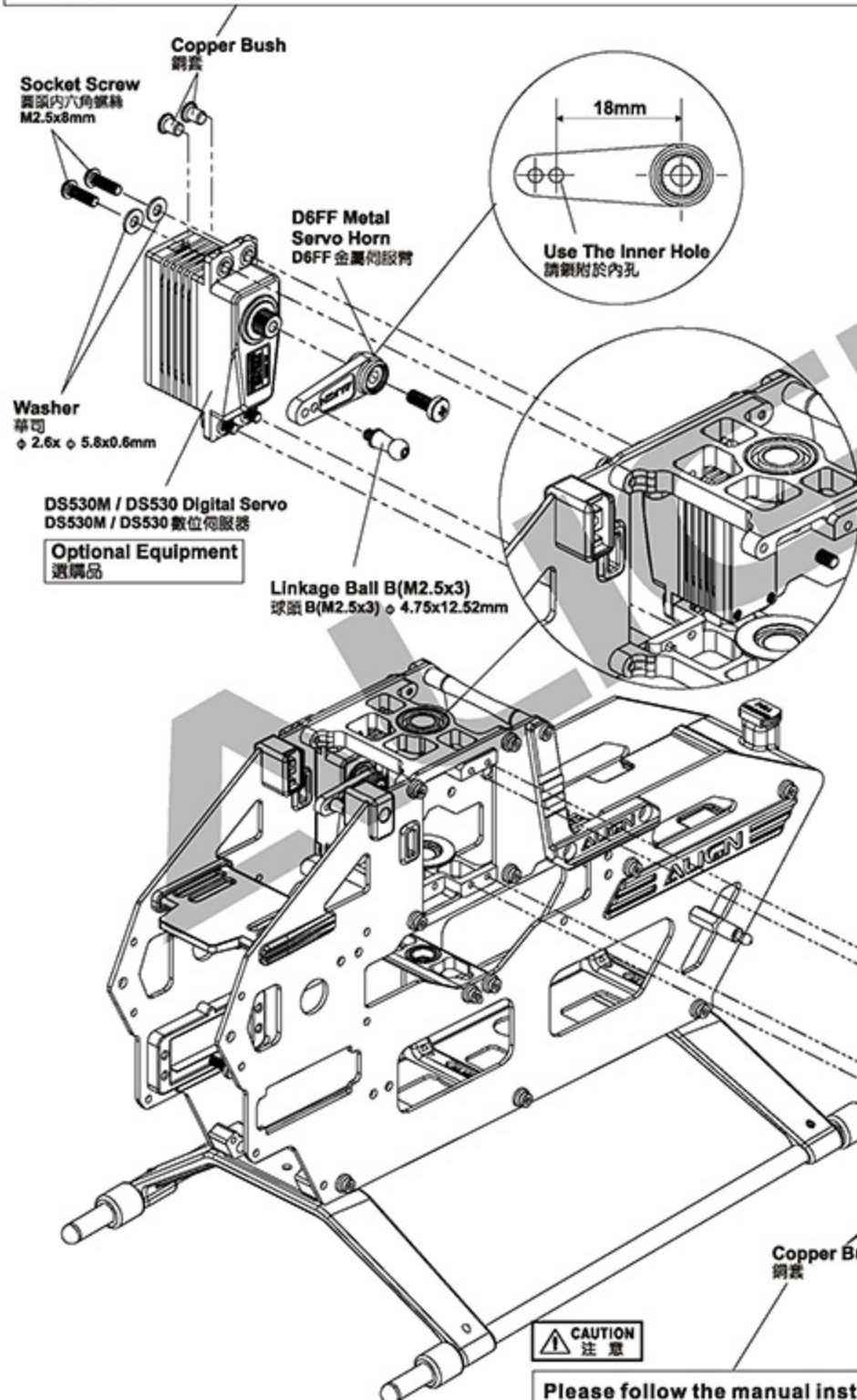

DS530 Digital Servo :

1. 1520 μs standard band / 1520 μs 實頻系統
2. Stall Torque/輸出扭力: 6.5kg.cm(6.0V)
9.0kg.cm(8.4V)
3. Motion Speed/動作速度: 0.085sec/60° (6.0V)
0.065sec/60° (8.4V)
4. Dimension/尺寸: 35.1 x 15.1 x 29mm
5. Weight/重量: 29g

DS530M Digital Servo :

1. 1520 μs standard band / 1520 μs 實頻系統
2. Stall Torque/輸出扭力: 6.5kg.cm(6.0V)
9.0kg.cm(8.4V)
3. Motion Speed/動作速度: 0.085sec/60° (6.0V)
0.065sec/60° (8.4V)
4. Dimension/尺寸: 35.1 x 15.1 x 29mm
5. Weight/重量: 36g

DS530M/DS530 Digital Servo

DS530M / DS530 數位伺服器

選購品

Linkage Ball B(M2.5x3)

球頭 B(M2.5x3) φ 4.75x12.52mm

D6FF Metal Servo Horn
D6FF 金屬伺服臂

Copper Bush
銅套

Washer
華司
φ 2.6x φ 5.8x0.6mm

Socket Screw
圓頭內六角螺絲
M2.5x8mm

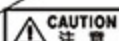

Please follow the manual instruction for servo washer and copper bush assembly. With the servo copper bush, the servo can be assembled properly to prevent screw over tightening or unbalanced force on screw.

伺服器墊圈與銅套須依照說明書指示安裝，銅套有定位防止螺絲鎖附不均與過度鎖附情況，所以安裝時不可漏裝銅套。

500HT18

Already assembled by factory,
please note to check again.
已組裝完成，請務必自行再確認。

Apply a small amount of T43 thread
lock when fixing a metal part.
螺絲鎖附於金屬件請使用適量T43(螺絲膠)。

Socket Screw
圓頭內六角螺絲 (M2.5x6mm) x 2

Socket Screw
圓頭內六角螺絲 (M2.5x8mm) x 2

Socket Button Head Screw
半圓頭內六角螺絲 (M2x8mm) x 2

Bearing
軸承 (φ 2x φ 4.5x2mm) x 4

Belt Pulley
皮帶輪 (φ 4.5x φ 8x7.2mm) x 2

Tension Spring
皮帶輪彈簧 (φ 4x φ 5.2x15mm) x 2

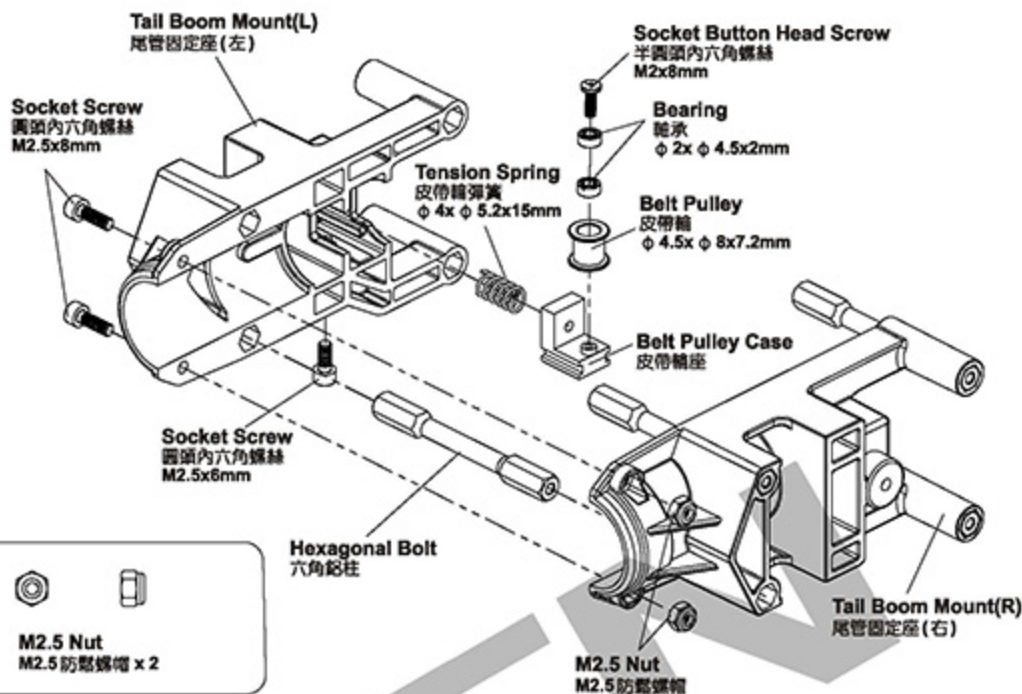

500HT18

CAUTION
注意

Original manufactory packages
contains product already assembled,
please confirm every screw is firmly
secured with T43. Do not use T43 on
any plastic part.

原裝零件出廠包裝如果是組裝品，請需再確認
各螺絲是否鎖緊上膠。請注意T43不可塗在任
何的塑膠材質上。

Socket Screw
圓頭內六角螺絲 (M2.5x8mm) x 8

Socket Screw
圓頭內六角螺絲 (M2.5x12mm) x 2

Washer
華司 (φ 2.6x φ 5.8x0.6mm) x 1

M2.5 Specialty Washer
M2.5特殊華司 (φ 2.5x φ 6x2mm) x 4

CAUTION
注意

Gently pull belt through the tail boom
in the direction from the tail to nose
of the helicopter.

請將皮帶由尾管固定座後方穿入機身內。

Tail Drive Belt
尾傳動皮帶

Washer
華司
φ 2.6x φ 5.8x0.6mm

Socket Screw
圓頭內六角螺絲
M2.5x12mm

M2.5 Specialty Washer
M2.5特殊華司

Socket Screw
圓頭內六角螺絲
M2.5x8mm

CAUTION
注意

Insert the screws; however, do not tighten! Insert the tail boom and belt, place the
belt over the pulley. Tighten all screws and confirm belt tension is correct.

先以螺絲虛鎖定位，待尾管及皮帶組裝完成後再確實鎖緊。

500HZ16

M2 Nut
M2 螺帽 x 1

Washer
華司 (φ 2.6x φ 5.8x0.6mm) x 4

Linkage Ball A(M2x3.5)
球頭A(M2x3.5)(φ 4.75x8.18mm) x 1

Socket Button Head Self Tapping Screw
半圓頭內六角自攻螺絲 (T2.6x10mm) x 4



Please follow the manual instruction for servo washer and copper bush assembly. With the servo copper bush, the servo can be assembled properly to prevent screw over tightening or unbalanced force on screw.

伺服器墊圈與銅套須依照說明書指示安裝，銅套有定位防止螺絲鎖附不均與過度鎖附情況，所以安裝時不可漏裝銅套。

Optional Equipment 選購品

DS535M / DS535 Digital Servo
DS535M / DS535 數位伺服器

DS535M Digital Servo:

- 1.1520 μs standard band / 1520 μs 寬頻系統
- 2.Stall torque/ 輸出扭力: 5.0kg.cm(6.0V)
6.5kg.cm(8.4V)
- 3.Motion speed/ 動作速度: 0.05sec/60° (6.0V)
0.035sec/60° (8.4V)
- 4.Dimension/ 尺寸: 35.1 x 15.1 x 29mm
- 5.Weight/ 重量: 36g

DS535 Digital Servo:

- 1.1520 μs standard band / 1520 μs 寬頻系統
- 2.Stall torque/ 輸出扭力: 5.0kg.cm(6.0V)
6.5kg.cm(8.4V)
- 3.Motion speed/ 動作速度: 0.05sec/60° (6.0V)
0.035sec/60° (8.4V)
- 4.Dimension/ 尺寸: 35.1 x 15.1 x 29mm
- 5.Weight/ 重量: 29g

500HB12

Rear Canopy Mounting Bolt
後機頭罩固定柱 (2.5x38.1mm) x 2

Apply a small amount of T43 thread lock when fixing a metal part.
螺絲鎖附於金屬件請使用適量T43(螺絲膠)。



Original manufactory packages contains product already assembled, please confirm every screw is firmly secured with T43. Do not use T43 on any plastic part.

原裝零件出廠包裝如果是組裝品，請再確認各螺絲是否鎖緊上膠。請注意T43不可塗在任何的塑膠材質上。

Rear Canopy Mounting Bolt
後機頭罩固定柱

Anti Rotation Bracket
十字擋板

Copper Bush
銅套

Washer
華司
M2 Nut
M2 螺帽

Socket Button Head Self Tapping Screw
半圓頭內六角自攻螺絲
T2.6x10mm

D5BF Servo Horn
D5BF 伺服器

Linkage Ball A(M2x3.5)
球頭A(M2x3.5)
φ 4.75x8.18mm

Use The Outermost hole
最外孔



Use the outermost hole from the end of servo horn when attaching ball. Remove the servo horn arms which are not used as pictured below.



500HB13

Socket Screw
圓頭內六角螺絲 (M2.5x5mm) x 3

Cross Screw
扁頭內六角螺絲 (M2.5x6mm) x 3

Hex Socket Self Tapping Screw
扁頭內六角自攻螺絲 (T3x6mm) x 3

Socket Screw
圓頭內六角螺絲
M2.5x5mm

Cross Screw
扁頭內六角螺絲
M2.5x6mm

Main Drive Gear Cover
主傳動輪蓋

80T Main Drive Gear
主傳動輪80T

Main Drive Gear Cover
主傳動輪蓋

Main Gear Case
主傳動輪座

Hex Socket Self Tapping Screw
扁頭內六角自攻螺絲
T3x6mm

Apply Grease
塗上潤滑油

One-way Bearing Shaft
單向輪承蓋

One-way Bearing
單向輪承
φ 10x φ 14x12mm

Main Gear Case
主齒中心座

Bearing
輪承
φ 10x φ 15x4mm

Slant Thread Main Drive Gear 134T
斜主齒輪 134T

500HB12



Socket Collar Screw
圓頭內六角軸套螺絲
(M2.5x16mm) x 1

500HZ21



500 Linkage Rod (E)
500 連桿 (E) (M2x20mm) x 3



Ball Link
連桿頭 x 6

500HH18A

Please add a main shaft spacer if necessary.
依需求加裝主軸墊片



Main Shaft Spacer (0.3)
主軸墊片 (0.3)
(φ 8.1x φ 12 x 0.3mm) x 1



Main Shaft Spacer (0.5)
主軸墊片 (0.5)
(φ 8.1x φ 12 x 0.5mm) x 1

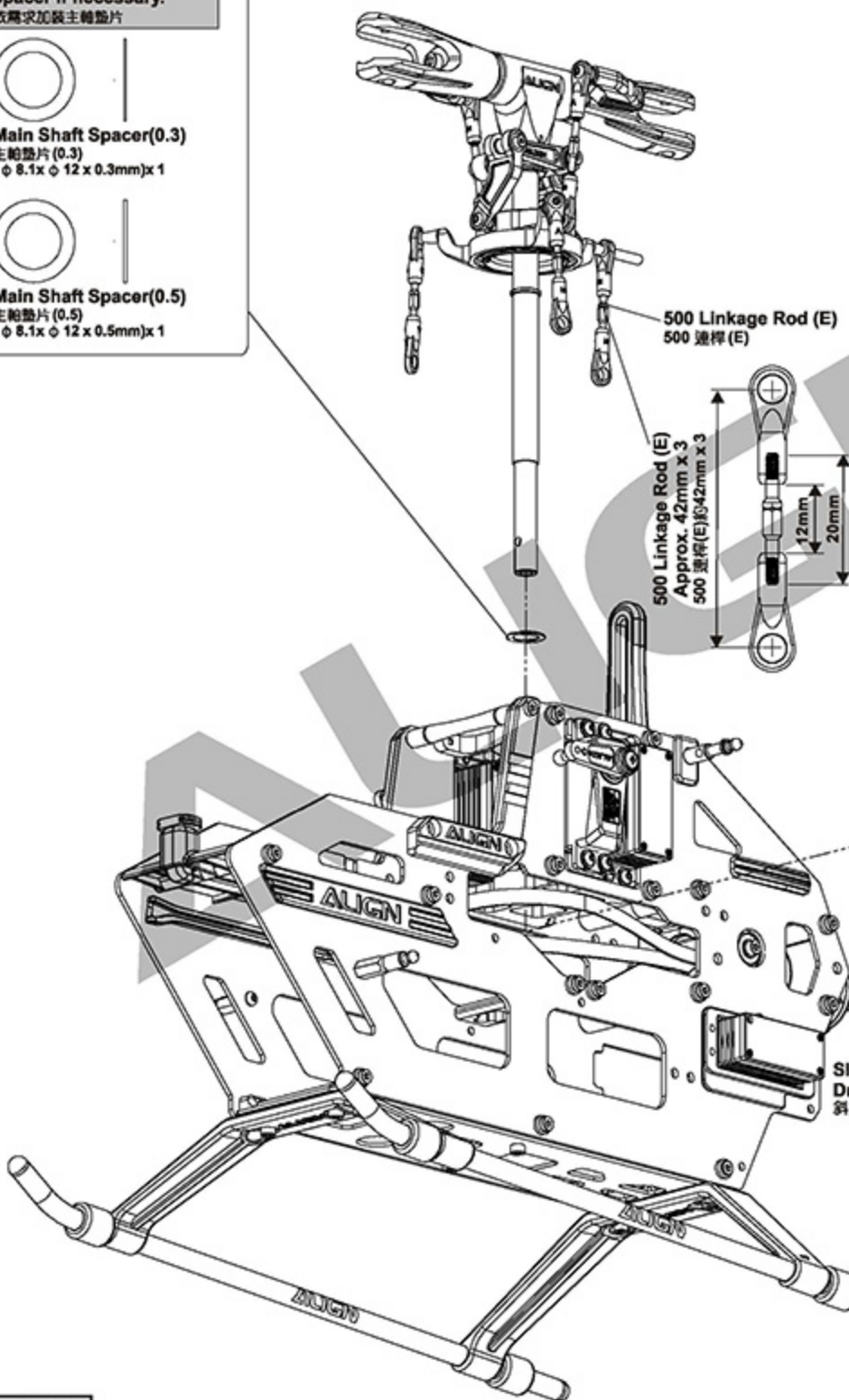

Apply a small amount of T43 thread lock when fixing a metal part.
螺絲鎖附於金屬件請使用適量T43(螺絲膠)。

CAUTION
注意

Original manufactory packages contains product already assembled, please confirm every screw is firmly secured with T43. Do not use T43 on any plastic part.

原裝零件出廠包裝如果是組裝品，請再確認各螺絲是否鎖緊上膠。請注意T43不可塗在任何的塑膠材質上。



CAUTION
注意

When using the Flybarless system, please use a swashplate leveler to level the swashplate. Adjust the length of servo linkage rods to make sure the swashplate is leveled before start set up of Flybarless configuration to ensure the gyro provides the best performance.

使用無平衡系統，請務必使用十字盤調整器校正十字盤，調整伺服連桿長度，確保十字盤達到水平狀態，再進行基本機體設定，這樣才能確保飛行性能達到最佳效果。

CAUTION
注意

Install the main shaft into the main drive gear after the belt has been installed, then align main shaft with the main shaft mounting sleeve, insert screw and tighten. DO NOT over tighten as this may cause damage of main shaft mounting sleeve.

請將組裝完成之主軸穿入已裝好皮帶的斜主齒輪組，穿入後對準主軸固定套上的孔位鎖附，並以適當扭力鎖附即可，過度鎖緊易造成主軸固定套滑牙。

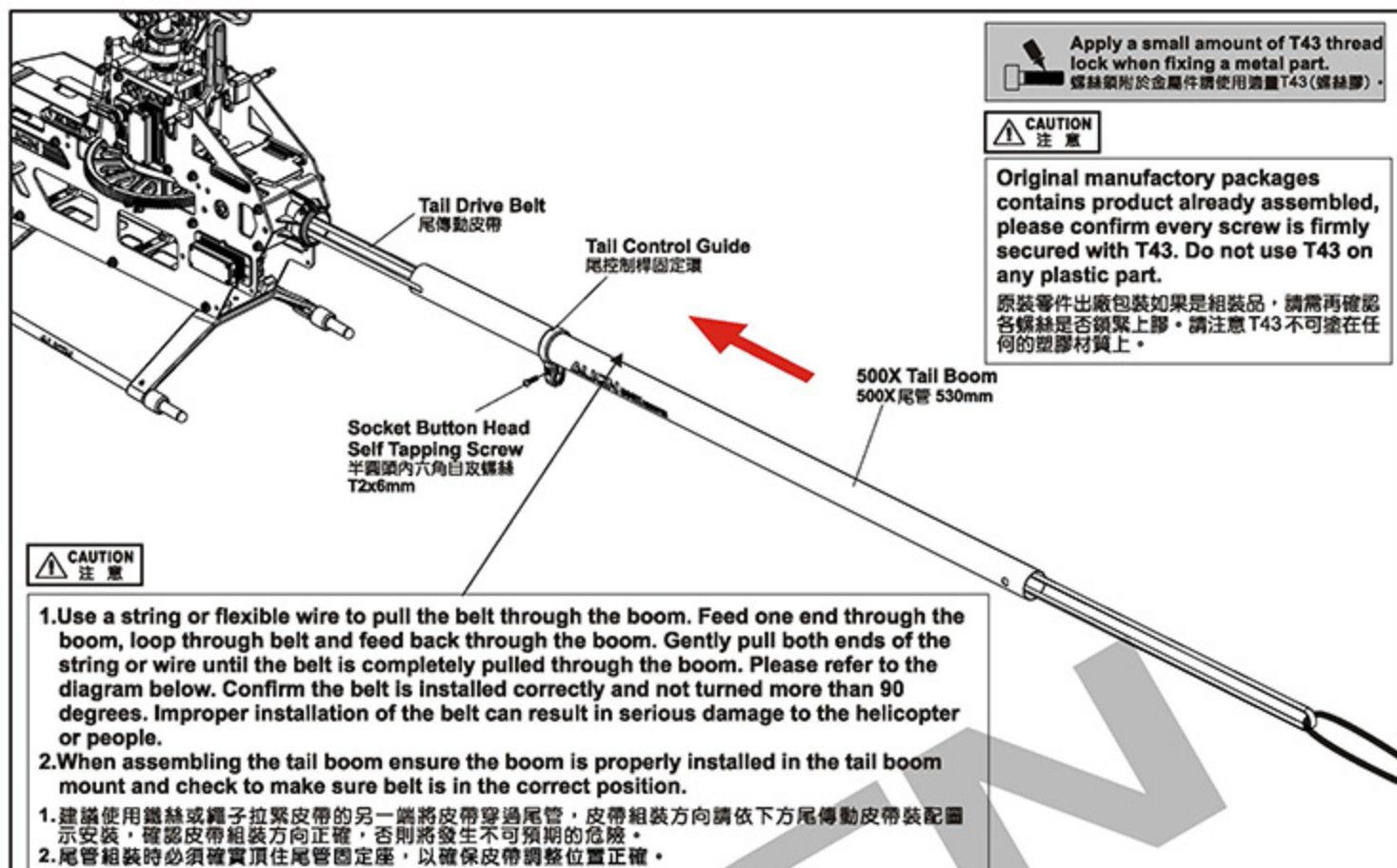

DRIVE BELT ILLUSTRATION

尾傳動皮帶裝配圖示

Front
前



WARNING 警告

DO NOT turn the belt greater than 90 degrees or the tail rotor system will fail.
皮帶組裝時須保持並行，嚴禁重疊交錯。



500HT19



Bearing
軸承 (φ 4x φ 9x4mm) x 2



Socket Screw
圓頭內六角螺絲 (M2.5x5mm) x 4



Socket Screw
圓頭內六角螺絲 (M2.5x14mm) x 1

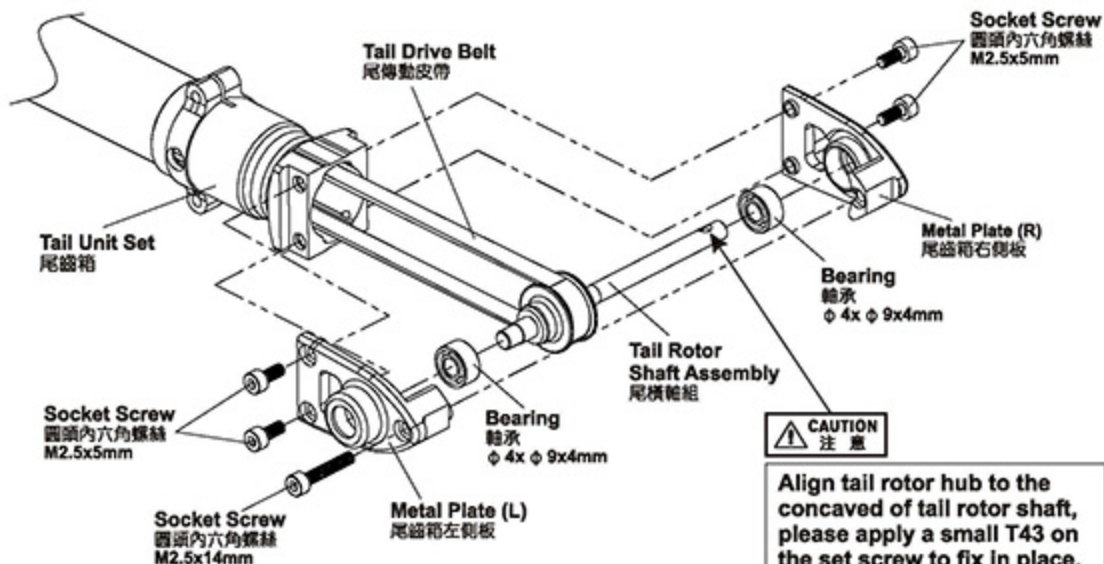

CAUTION 注意

Align tail rotor hub to the concaved of tail rotor shaft, please apply a small T43 on the set screw to fix in place.
尾槓與T型座座端準尾槓軸的凹刻並鎖上，請確認止洩螺絲上膠。

Apply a small amount of T43 thread lock when fixing a metal part.
螺絲鎖附於金屬件請使用適量T43(螺絲膠)。

CAUTION
注意

Original manufactory packages contains product already assembled, please confirm every screw is firmly secured with T43. Do not use T43 on any plastic part.

原裝零件出廠包裝如果是組裝品，請需再確認各螺絲是否鎖緊上膠。請注意 T43 不可塗在任何的塑膠材質上。

500HT19

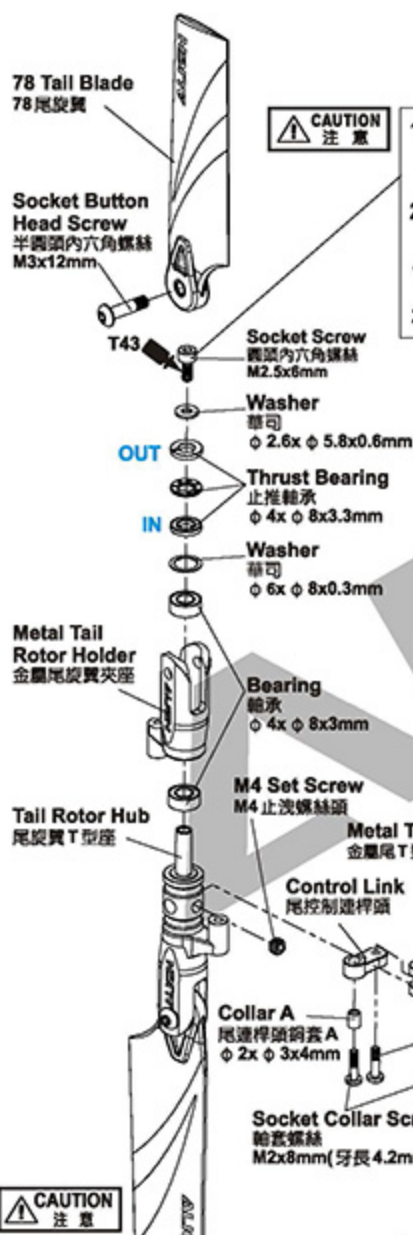
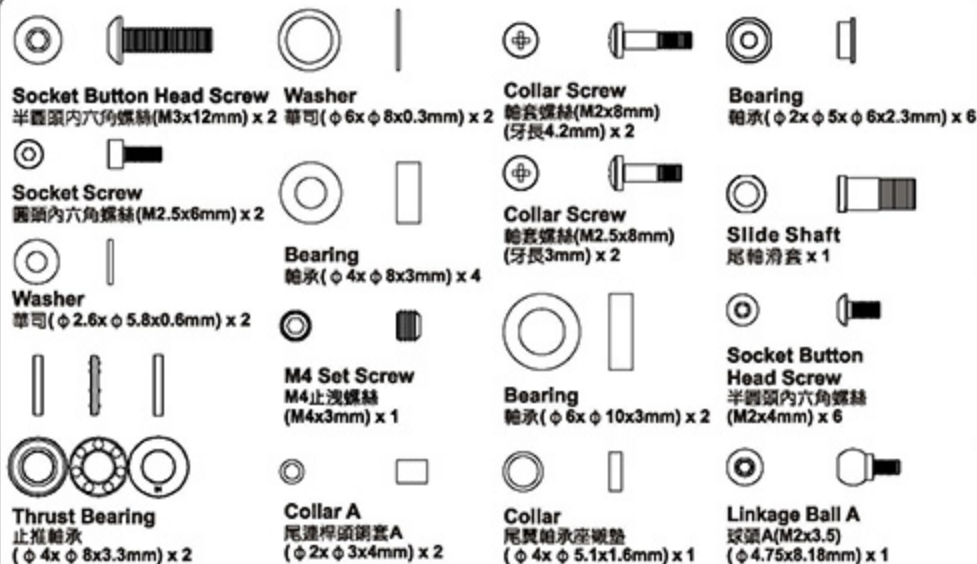

- CAUTION** 注意
- The Metal Tail Rotor Holder is assembled at the factory, make sure to apply little thread lock on screws and tighten them back appropriately before starting to fly. Suggest to use torque wrench or torque lock for tightening screws with the torque value 4.0kg.cm.
 - Make sure to tighten the screws on each side with equal average strength, equal torque, or there may be imbalance during rotation.

1.尾旋翼夾座出廠為假組裝，螺絲必須使用適量螺絲膠重新鎖附，鎖附需注意適當緊度即可，建議搭配扭力或扭力機鎖附，扭力值為4.0kg.cm。
2.組裝尾控制組時，上、下螺絲必須平均力道鎖附，不可單邊過緊，否則會造成干涉滑動不順暢。

CAUTION
注意

While assembly the slide shaft, please use suitable amount of T43 on the thread. Please do not use R48 or other high strength thread lock to avoid damages while maintenance or repairs.

組立尾輪滑套時，請使用適量的T43螺絲膠在螺牙上，嚴禁使用R48高膠合性軸承膠防止膠合過緊，以避免日後拆修維護零件之損傷。

CAUTION
注意

The tail rotor hub and screws are wear items, and thus should be inspected for replacement after every 100 flights. For flights with high head speed, the inspection interval should be reduced to ensure flight safety.

尾旋翼T型座和螺絲屬於飛行消耗品，建議每100趟定期檢查及更換，高主旋翼轉速飛行時，請縮短定期檢查之週數，以確保飛行安全。

CAUTION
注意

Any slight binding on control link may affect tail action during flight. Please be note while tightening M2x8mm collar screw, please adjust the ball link and make sure it is operating smoothly. Apply suitable amount of T43 on the thread.

尾控制連桿頭若微干涉、動作不順暢，將影響尾舵鎖定效果，請注意鎖附M2x8mm輪套螺絲時，須調整至連桿頭可滑順轉動的程度，並使用適量T43螺絲膠固定。

CAUTION
注意

After complete the tail rotor assembly, please check if it rotates smoothly.

尾旋翼組裝完成後需確認尾旋翼夾座轉動滑順。

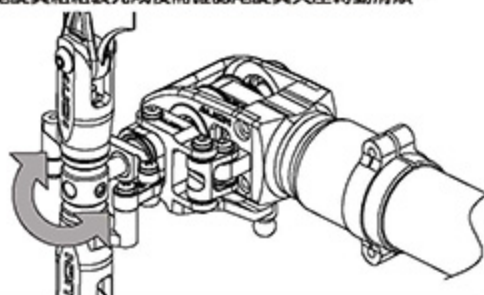

500HT20

500 Linkage Rod(A)
500 連桿 (A) x 2



Carbon Tail Control Rod Sleeve
碳纖維尾控制桿套
($\phi 2.4 \times \phi 5 \times 10 \text{mm}$) x 2



Ball Link
連桿頭 x 2

500HT19



Washer
華司 ($\phi 2.6 \times \phi 5.8 \times 0.6 \text{mm}$) x 2



Socket Screw
圓頭內六角螺絲 (M2.5x25mm) x 2



M2.5 Specialty Washer
M2.5 特殊華司 ($\phi 2.5 \times \phi 6 \times 2 \text{mm}$) x 4



Socket Screw
圓頭內六角螺絲 (M2.5x10mm) x 4

Apply a small amount of T43 thread lock when fixing a metal part.
螺絲鎖附於金屬件請使用適量 T43 (螺絲膠)。



Original manufactory packages contains product already assembled, please confirm every screw is firmly secured with T43. Do not use T43 on any plastic part.

原裝零件出廠包裝如果是組裝品，請再確認各螺絲是否鎖緊上膠。請注意 T43 不可塗在任何的塑膠材質上。

When assembling the tail boom, please aim at the fixing hole $\phi 3$.

裝入尾管時請注意孔對準尾管 $\phi 3$ 固定孔

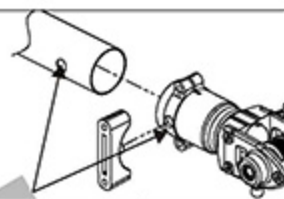

Before assembling, please wrap the tail boom with a scotch tape (Thickness 0.03~0.05mm) to avoid the mount slipping.
安裝前請先用透明膠帶 (0.03~0.05mm 厚) 包覆尾管，可防止固定座滑動。

Socket Screw
圓頭內六角螺絲
M2.5x10mm

M2.5 Special Washer
M2.5 特殊華司

Horizontal Stabilizer
水平翼

Stabilizer Mount (Upper)
水平翼固定上座

Tail Control Guide
尾控制桿固定環

M2.5 Special Washer
M2.5 特殊華司

Socket Screw
圓頭內六角螺絲
M2.5x25mm

Vertical Stabilizer Mount
垂直固定座

Stabilizer Mount (Lower)
水平翼固定下座

Socket Screw
圓頭內六角螺絲
M2.5x10mm

Washer
華司
 $\phi 2.6 \times \phi 5.8 \times 0.6 \text{mm}$

Vertical Stabilizer
垂直翼

Washer
華司
 $\phi 2.6 \times \phi 5.8 \times 0.6 \text{mm}$

Socket Screw
圓頭內六角螺絲
M2.5x10mm

Tail Boom Brace Set
尾管支撐組

Carbon Tail Control Rod Assembly
碳纖維尾控制桿組

500 Linkage Rod(A)
500 連桿 (A)

Ball Link
連桿頭

Carbon Tail Control Rod Sleeve
碳纖維尾控制桿套
 $\phi 2.4 \times \phi 5 \times 10 \text{mm}$

500HB12A



Washer
華司 ($\phi 2.6 \times \phi 5.8 \times 0.6 \text{mm}$) x 2



Socket Screw
圓頭內六角螺絲 (M2.5x10mm) x 2

500HH18A

Main Blade Fixing Screw

鎖主旋翼用螺絲



Socket Collar Screw
圓頭內六角軸套螺絲 (M3x20mm) x 2



M3 Nut
M3 防鬆螺帽 x 2

Apply a small amount of T43 thread lock when fixing a metal part.
螺絲鎖附於金屬件請使用適量T43(螺絲膠)。



CAUTION
注意

Original manufactory packages contains product already assembled, please confirm every screw is firmly secured with T43. Do not use T43 on any plastic part.

原裝零件出廠包裝如果是組裝品，請再確認各螺絲是否鎖緊上膠。請注意T43不可塗在任何的塑膠材質上。

Socket Collar Screw
圓頭內六角軸套螺絲
M3x20mm

When tightening the main blade fixing screw, please tighten it firmly, but not over tighten, or it may cause the damage of main blade holder and result in danger.

鎖緊主旋翼螺絲須注意適當緊度即可，過緊可能導致主旋翼夾座受損，飛行意外發生。

M3 Nut
M3 防鬆螺帽

470 Carbon Fiber Blades
470 碳纖維旋翼

500HB12



Socket Screw
圓頭內六角螺絲 (M3x8mm) x 4

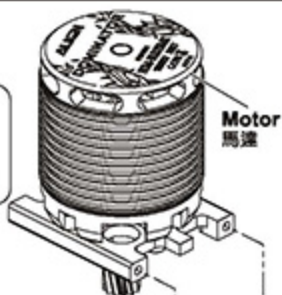

Original manufactory packages contains product already assembled, please confirm every screw is firmly secured with T43. Do not use T43 on any plastic part.

原裝零件出廠包裝如果是組裝品，請再確認各螺絲是否鎖緊上膠。請注意T43不可塗在任何的塑膠材質上。

500HB12A



Socket Screw
圓頭內六角螺絲 (M3x10mm) x 2



Set Screw
M3 止洩螺絲 (M3x3mm) x 1



Washer
華司
(ϕ 3x ϕ 8x1mm) x 2

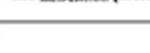

Socket Screw
圓頭內六角螺絲
M3x10mm



Set Screw
止洩螺絲
M3x3mm

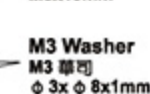

M3 Washer
M3 華司
 ϕ 3x ϕ 8x1mm

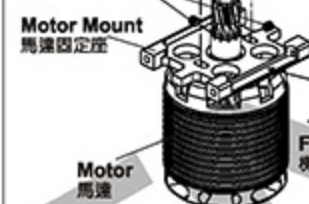

Please keep 500X Motor Mount concave face toward the hell nose. 馬達固定座凹槽處請朝機頭方向。

Socket Screw
圓頭內六角螺絲
M3x8mm

Apply a small amount of T43 thread lock when fixing a metal part. 螺絲鎖附於金屬件請使用適量T43(螺絲膠)。

BELT TENSION ADJUSTMENT SUGGESTION:

1. Adjust belt tension to ensure proper power transfer to the tail. To prevent excessive power consumption DO NOT over tighten belt.
2. Adjust both screws equally to tighten or loosen belt tension. Turn each screw approximately 1~1.5 turns to achieve the appropriate belt tension. Both sides must be rotated equally.
3. Make sure to check belt tension prior to each flight and adjust accordingly. To loosen belt tension, turn clockwise. To tighten belt tension, turn counterclockwise.

皮帶鬆緊調整建議：

1. 正確的調整皮帶鬆緊度，以確保飛行動力確實傳遞至尾部；皮帶不宜過緊，以免動力損耗。
2. 鎖緊兩側皮帶壓輪的調整螺絲後，再各放1~1.5圈為最佳的皮帶鬆緊度，調整時務必將兩側的調整螺絲同時放鬆或鎖緊。
3. 每趟飛行前，請務必檢查調整螺絲的鬆緊度，順時針旋轉可將皮帶調整；逆時針旋轉則將皮帶調整。

Used to adjust the belt tension by tightening or loosening the screw. 鎖/放螺絲來調整皮帶鬆緊

Set the motor pinion gear to main drive gear mesh to approximately 0.1mm to avoid excess power consumption motor burnt due to overload.

馬達前後可移動請保持兩齒輪咬合處約有0.1mm間隙，過緊咬合將造成動力損失或馬達高阻力的過載，嚴重可能導致馬達燒毀。

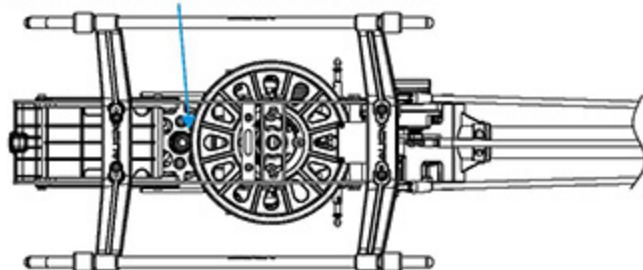

The lower edge of main gear need to be lined up with lower edge of pinion gear. This will ensure smooth meshing, and avoid interference between pinion's base and main gear which can lead to unusual wear.

馬達齒下緣必須與主齒盤下緣水平切齊，如此才能確保齒輪傳動順暢，避免馬達主齒根部與新型斜主齒輪產生異常干涉磨損。

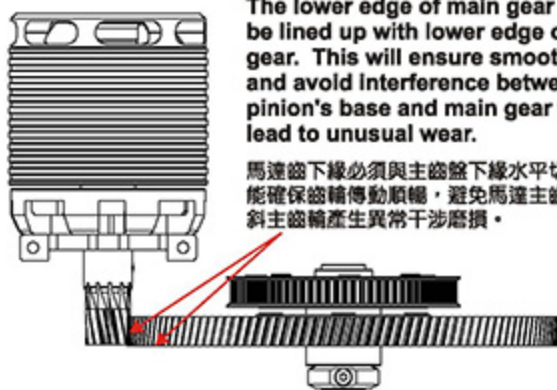



CAUTION
注意

A MOUNTING ORIENTATION OF MICROBEAST PLUS MICROBEAST PLUS的安裝方向



Please visit Align download area to get the completed instruction manual at Align website.

更多詳細的設定操作說明請至官網下載專區下載。
<http://www.align.com.tw/beastx/>

Microbeast PLUS provides 8 different direction choices can be installed on any position of helicopter.

Microbeast PLUS 提供8種不同方向選擇，可以安裝在機體的任何一個位置。

THE COLOR OF THE STATUS-LED SHOWS THE CURRENTLY SELECTED ORIENTATION:

LED指示燈狀態顯示安裝方向：



Status LED Off*
Status-LED 燈熄滅*



Status LED Flashing Purple
Status-LED 燈紫色閃爍



Status LED Purple
Status-LED 燈紫色



Status LED Flashing Red
Status-LED 燈紅色閃爍



Status LED Red
Status-LED 燈紅色



Status LED Flashing Blue
Status-LED 燈藍色閃爍



Status LED Blue
Status-LED 燈藍色



Status LED Flashing Red/Blue
Status-LED 燈紅色/藍色同時閃爍

Front
機頭方向

* Factory Setting * 出廠預設值



Apply a small amount of T43 thread lock when fixing a metal part.
鎖緊螺絲於金屬件請使用適量T43(螺絲膠)。



CAUTION
注意

Original manufactory packages contains product already assembled, please confirm every screw is firmly secured with T43. Do not use T43 on any plastic part.

原裝零件出廠包裝如果是組裝品，請需再確認各螺絲是否鎖緊上膠。請注意T43不可塗在任何的塑膠材質上。

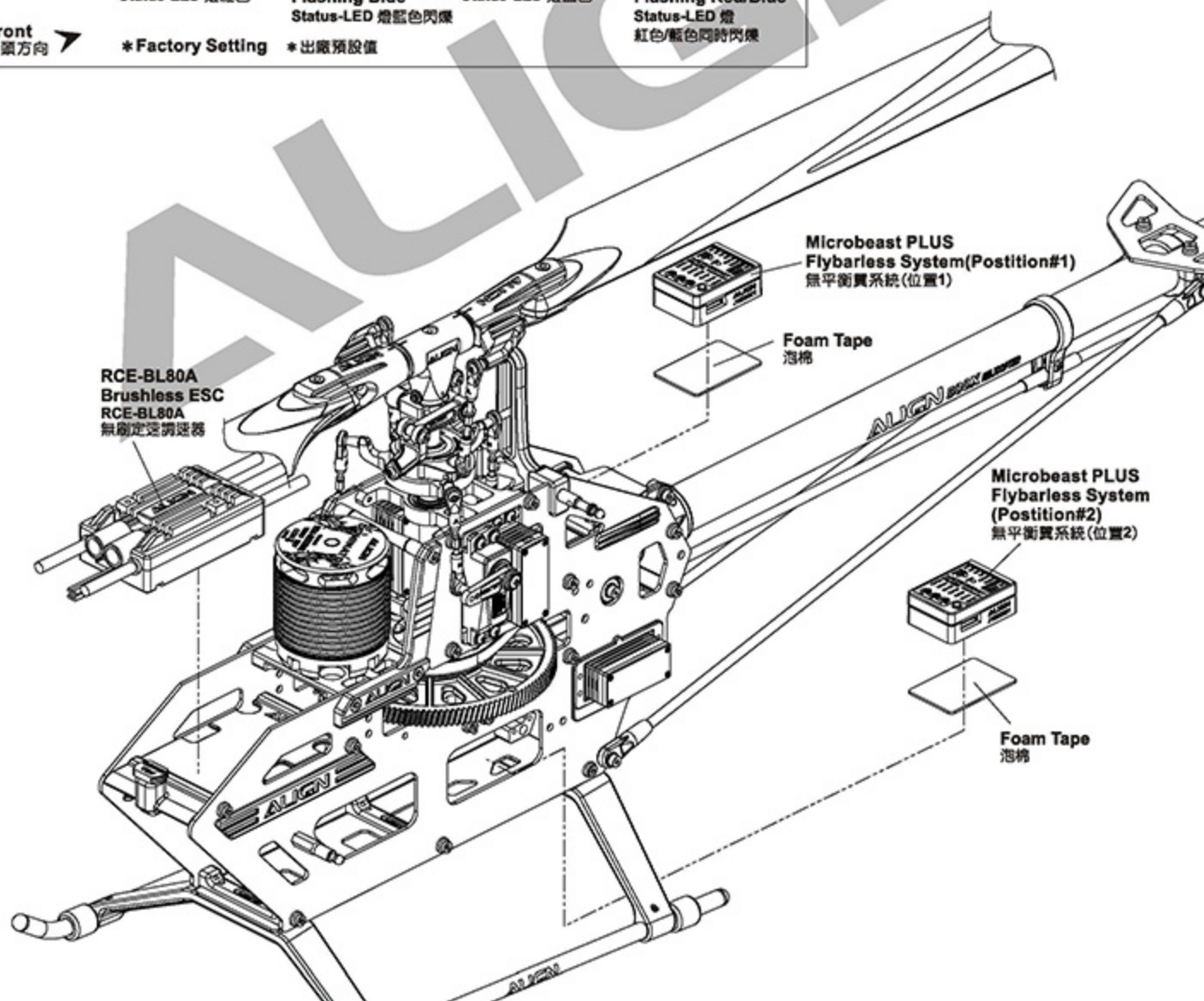

Compatible Battery/ 適用電池
6S 22.2V 2,600mAh to 3,300mAh.

Max battery size
可容納電池最大尺寸

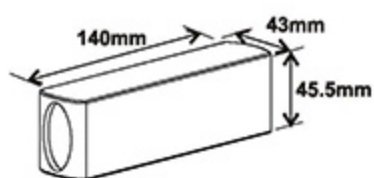

Slide the battery mounting plate along the rail until a "click" is heard to make sure the battery mounting plate is latched.

將電池固定板順著電池滑軌裝入至發出“喀答”聲響，使電池固定板卡入卡榫。

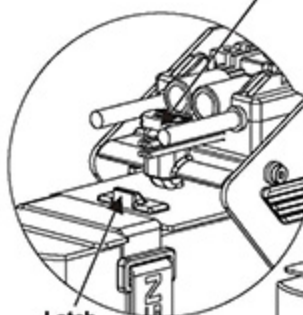

Latch
卡榫

While drawing out the battery, pull this latch to allow the battery to slide out along the rail.

電池抽出時，請先將拉扣往上拉順著滑軌抽出。

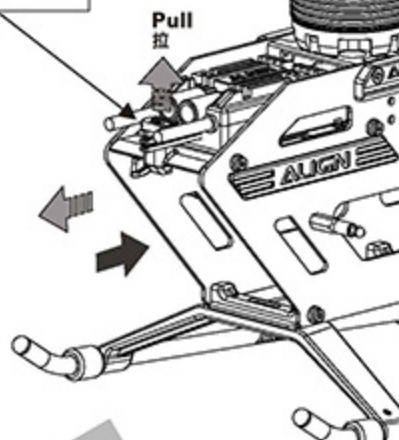

Please attach the hook & loop tape to narrow side of battery.
魔術沾請黏貼在電池的較窄面。

Battery Mount

電池固定板
Battery
電池

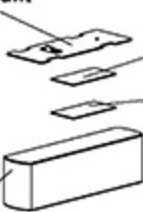

Hook and Loop Tape (Hooked)

魔術沾(勾狀)

Hook and Loop Tape (Fuzzy)

魔術沾(絨毛狀)

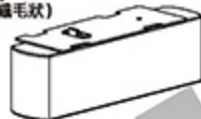

1 cm above
1公分以上

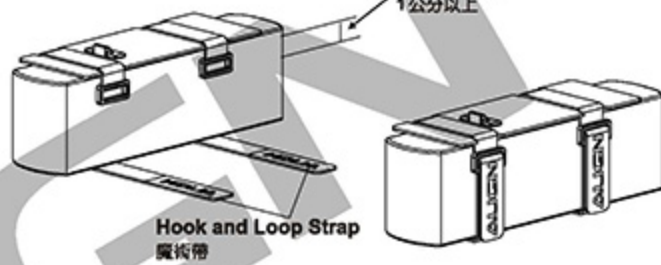

Hook and Loop Strap
魔術帶

CANOPY ASSEMBLY

機頭罩安裝

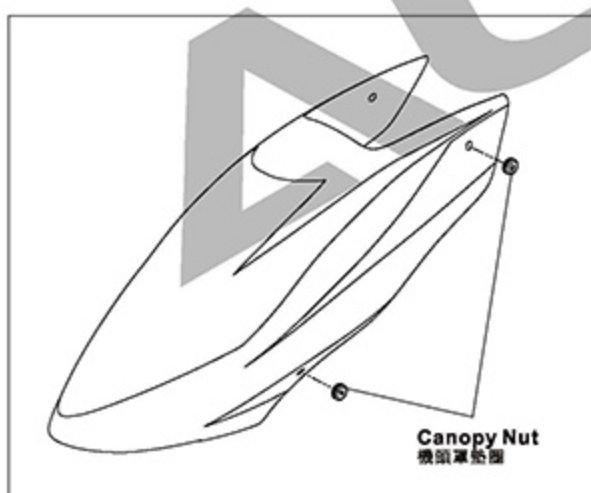

Canopy Nut
機頭罩螺帽

Canopy
機頭罩

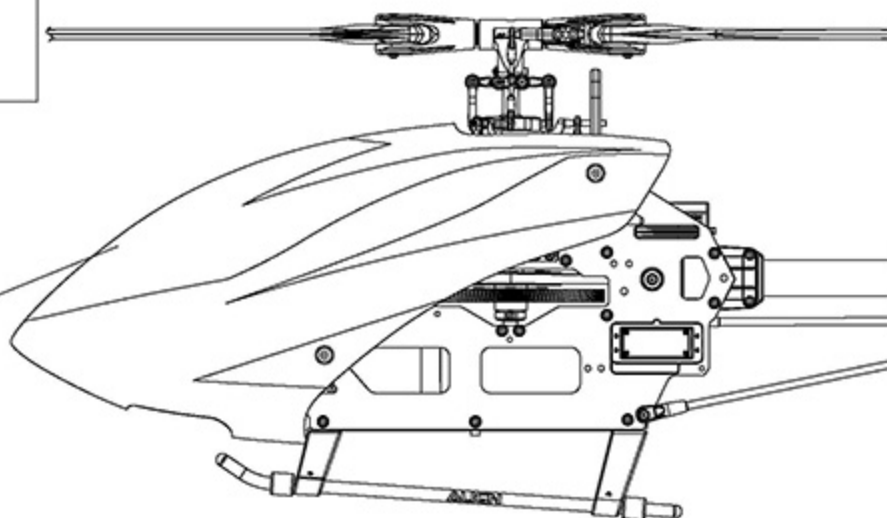

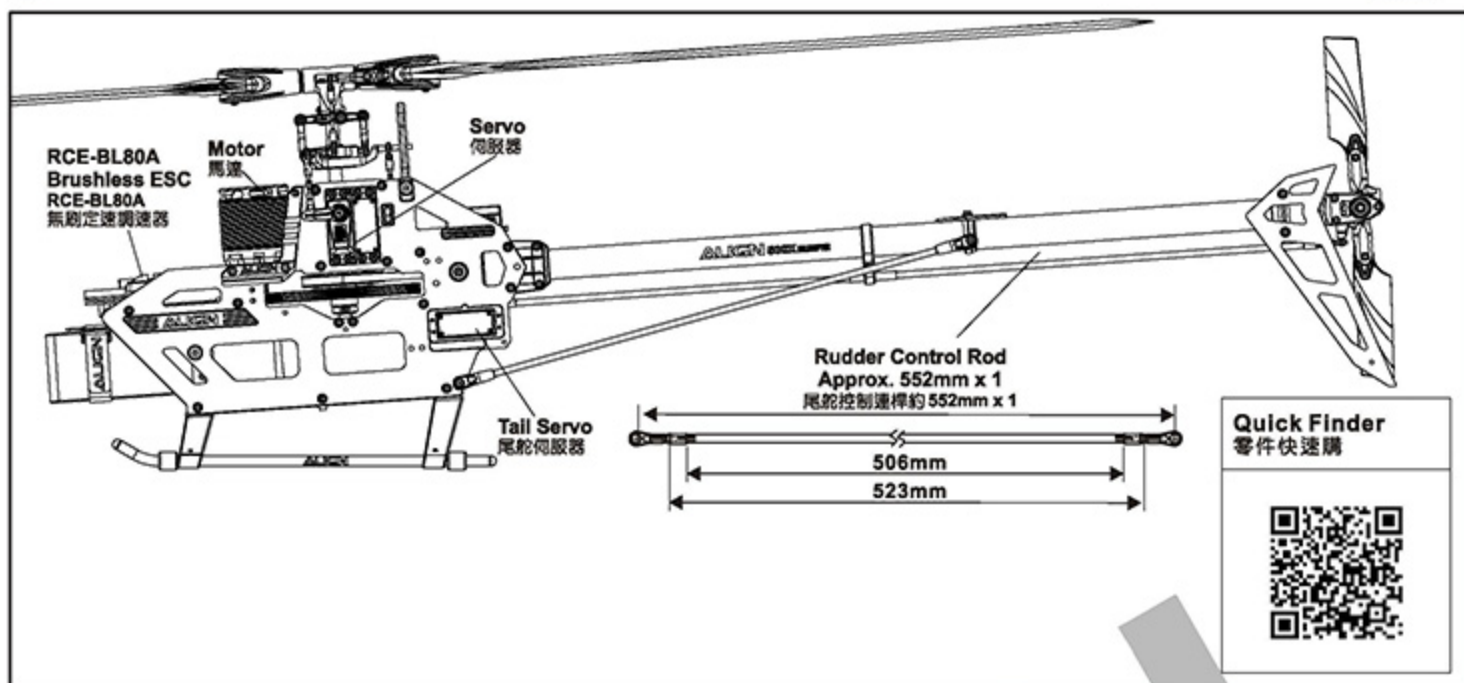

MICROBEAST PLUS FLYBARLESS MANUAL

無平衡翼系統使用說明

ALIGN

MICROBEAST PLUS Flybarless System as ALIGN helicopter standard equipment, must and compatible with ALIGN standard equipment including blades, servos, motor, battery and so on, please refer to flight and setup instruction in this manual.

ALIGN 直昇機使用 MICROBEAST PLUS 無平衡翼系統，須搭配 ALIGN 直昇機標準配件(主旋翼、伺服器、馬達)與飛行操作、設定指示。

USER NOTICE 使用注意事項



1. If assembling and operating the helicopter without using ALIGN standard equipment, including electronic equipment & blades...etc, please make sure there is a sufficiently large and stable power supply to your helicopter. If there is any abnormal voltage or insufficient power supply, suggest to upgrade the flybarless system to MICROBEAST PLUS HD (Optional) for better power back up.
 2. Please refer to BEASTX MICROBEAST PLUS/HD website for MICROBEAST PLUS/HD assembly and setup instruction.
 3. Any over use, incorrect setup, missassembly, incorrect modification or misuse will lead to abnormal voltage, electronic devices damage, structural interference, and insufficient power supply. Make sure to carefully check every assembly and setup refer to the manual instruction prior to every flight to prevent any unforeseen danger.
1. 安裝、操控您的直昇機時，如非使用 ALIGN 標準配件(含電子配件、主旋翼等)，請務必確定您的供電系統有足夠的供電能力，如發現電壓異常、供電不足，建議您升級使用 MICROBEAST PLUS HD 無平衡翼系統(選配)，以能確保充足、穩定的接收器電源。
 2. MICROBEAST PLUS/HD 使用、設定、接線，請參照 BEASTX MICROBEAST PLUS/HD 官方說明。
 3. 任何電子配件、零件的設定、組裝、修改或操作不良所造成的電壓異常、電子零件損壞，即可能造成供電不穩定等問題，每趟飛行前須注意仔細檢查，防止機件及電子零件故障而引發不可預期的意外。

MANUAL LINK 設定操作連結

MICROBEAST PLUS Flybarless System is the latest version out of the factory, please feel at ease using it. You can also link to BEASTX MICROBEAST PLUS/HD website to get the latest version and the latest news. MICROBEAST PLUS Flybarless System has available some different versions, each version has different programming and function, please make sure your Microbeast version and read its correct manual carefully before assembly or upgrading, especially you are upgrade from version V3.2.X. to V.4.X.X by yourself, in order to avoid mistake or loss by any misunderstanding, please be sure that you have correct version and follow its setting method accordingly. And please refer to MICROBEAST PLUS V3.2.x and V4.2 instruction manual for operating and setting.

MICROBEAST PLUS 無平衡翼系統，出廠時主程式已是最新版本。您也可以連結至 BEASTX MICROBEAST PLUS/HD 官網查詢，隨時更新最新版本及各項最新訊息。部分版本因升級而設定及功能會有所不同，請確定您的版本並詳閱其說明書，尤其您是由 V3.2.x 升級至 V.4.x.x，請務必深入了解版本之間的設定功能，以免錯誤而造成損失。操作設定請同時參照 V3.2.x 版及 V4.2 版使用說明書。



Please visit Align download area to get the completed instruction manual at Align website.

更多詳細的設定操作說明請至官網下載專區下載。
<http://www.align.com.tw/beast/>



MICROBEAST PLUS
MARKET NEW! FLYBARLESS SYSTEM PLUS HD/PLUS HD

PARTS IDENTIFICATION 各部位名稱

MICROBEAST PLUS FLYBARLESS SYSTEM 無平衡翼系統

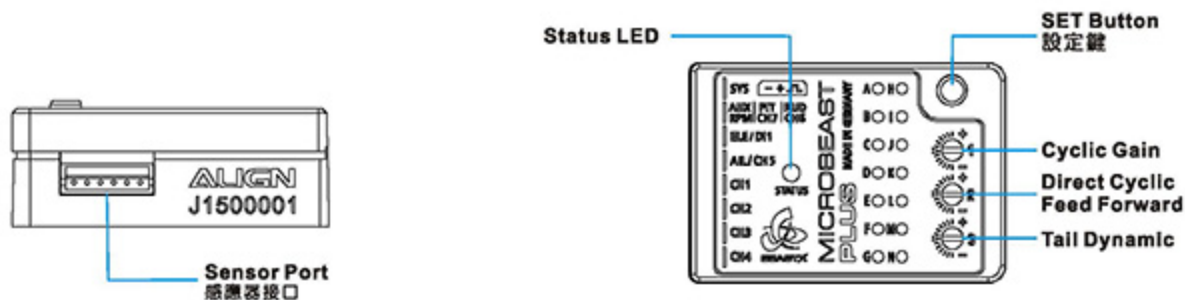

MICROBEAST PLUS FLYBARLESS SYSTEM WIRING DIAGRAM 無平衡翼系統接線示意圖

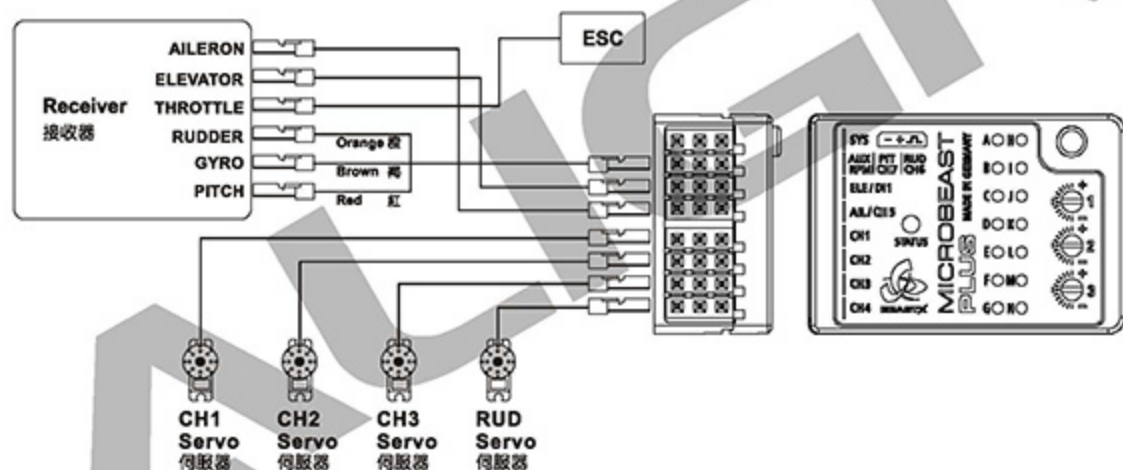

For detail connectivity, please scan QR Code then follow MICROBEAST PLUS manual.

詳細接線方式，請掃描QR Code連結至MICROBEAST PLUS說明書。



CAUTION
注意



MICROBEAST PLUS HD Flybarless System(Optional) MICROBEAST PLUS HD無平衡翼系統(選配)

If assembling and operating the helicopter without using ALIGN standard equipment, including electronic equipment & blades...etc, please make sure there is a sufficiently large and stable power supply to your helicopter. If there is any abnormal voltage or insufficient power supply, suggest to upgrade the flybarless system to MICROBEAST PLUS HD (Optional) for better power back up. Please refer to BEASTX website for MICROBEAST PLUS HD assembly and setup instruction.

安裝、操控您的直昇機時，如非使用ALIGN標準配件(含電子配件、主旋翼等)，請務必確定您的供電系統有足夠的供電能力，如發現電壓異常、供電不足，建議您升級使用MICROBEAST PLUS HD無平衡翼系統(選配)，以能確保充足、穩定的接收器電源。MICROBEAST PLUS HD使用、設定、接線，請參照MICROBEAST PLUS HD官方說明。

To set this option is to turn on the transmitter and connect to BEC power.

Note: For the safety, please do not connect ESC to the brushless motor in order to prevent any accident caused by the motor running during the setting.

此項設定只要開啟發射器，接上BEC電源即可進行操作。

注意：為了安全起見，設定前請先不要將無刷調速器與無刷馬達三條線接上，以免調整時啟動馬達而發生危險。

SERVO CONFIGURATION 伺服器配置

Following the servo configuration diagram on right, plug the servos to Gyro.

請依照右圖顯示的伺服器名稱，將伺服器接到陀螺儀。

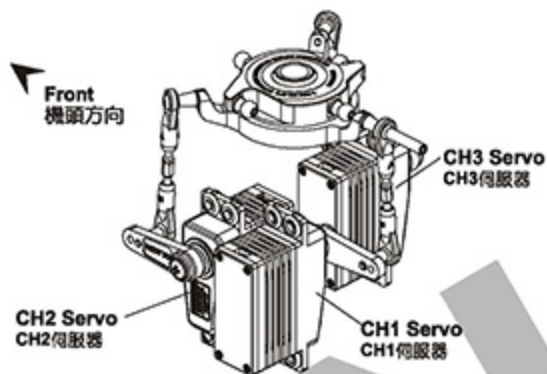

ADJUSTMENTS FOR GYRO AND TAIL NEUTRAL SETTING

陀螺儀與尾翼中立點設定調整

Turn off Revolution mixing (RVMX) mode on the transmitter, then set the gain switch on the transmitter and the gyro to non-head lock mode, or disable gain completely. After setting the transmitter, connect the helicopter power and proceed with rudder neutral point setting.

Note: When connecting to the helicopter power, please do not touch tail rudder stick and the helicopter, wait for 3 seconds for gyro to enable, and the rudder servo horn should be 90 degrees to the tail control pushrod. Tail pitch slider should be halfway on the tail output shaft. This will be the standard rudder neutral point. After completing this setting, set the gain switch back to heading lock mode, with gain at around 70%.

發射器內陀螺儀設定請關閉根輪混控模式，並將發射器上的感度開關與陀螺儀切至“非鎖定模式”或將陀螺儀感度關閉。發射器設定完成後接上直昇機電源，即可進行尾舵中立點設定。

注意：當接上直昇機電源時請勿碰動尾舵搖桿或碰觸機體，待3秒陀螺儀開機完成後，尾舵伺服臂與尾舵控制桿約成90度，尾旋翼控制組須正確置於尾橫軸約中間位置，即為標準尾舵中立點設定，設定完成後，切換至“鎖定模式”，感度設約70%左右。

TAIL NEUTRAL SETTING 尾中立點設定

After the gyro is enable and under non-head lock mode, correct setting photo. If the tail pitch assembly is not in the middle position, please adjust the length of rudder control rod to trim.

陀螺儀開機後，在非鎖定模式下，尾舵控制組與尾Pitch控制組正確擺置位置。

若尾Pitch控制組未置中時請調整尾控制連桿的長度來修正。

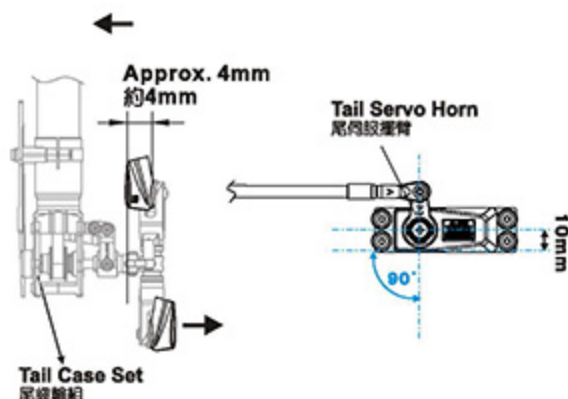

HEAD LOCK DIRECTION SETTING OF GYRO 陀螺儀鎖定方向設定

To check the head lock direction of gyro is to move the tail counterclockwise and the tail servo horn will be trimmed counterclockwise. If it trims in the reverse direction, please switch the gyro to "REVERSE".

陀螺儀鎖定方向確認，當手搖尾部反時鐘擺動，尾舵伺服臂應反時鐘修正，反向時請切換陀螺儀上“鎖定反向”開關修正。

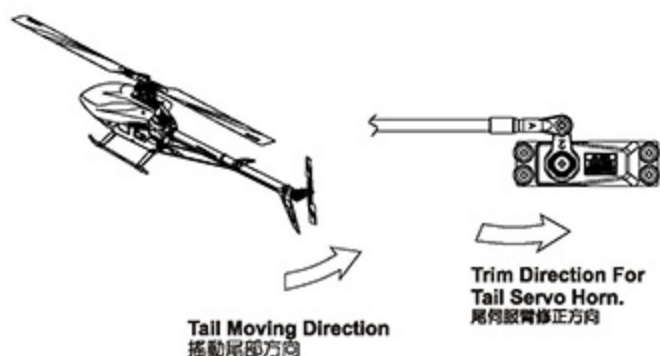



The rotational speed must set below 3,200RPM for safety to prevent any unexpected danger.
直昇機的主旋翼有安全使用轉速範圍，飛行時不可超過3,200 RPM，超轉會導致不可預期的危險，甚至危害他人生命財產。

GENERAL FLIGHT 一般飛行模式

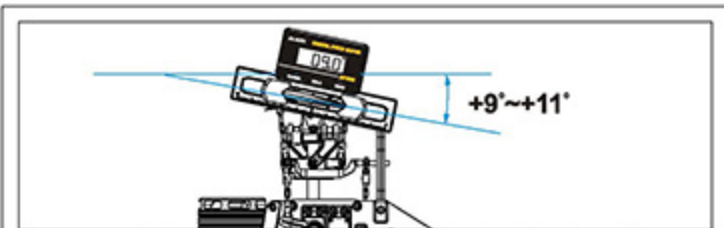

Stick Position at High/Throttle 100%/Pitch +9~+11°
搖桿高速/油門100%/Pitch +9~+11°

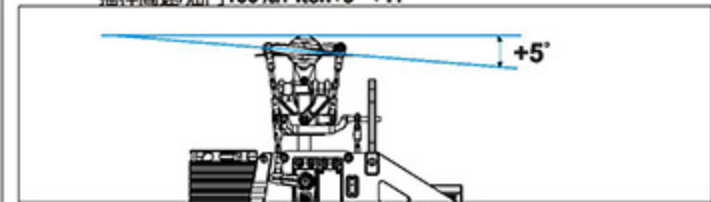

Stick Position at Hovering/Throttle 65~70%/Pitch +5~+6°
搖桿停懸/油門65~70%/Pitch +5~+6°

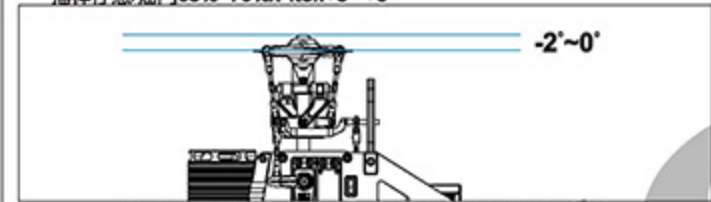

Stick Position at Low/Throttle 0%/Pitch -2~0°
搖桿低速/油門0%/Pitch -2~0°

3D FLIGHT 3D特技飛行模式



Stick Position at High/Throttle 100%/Pitch +11°
搖桿高速/油門100%/Pitch +11°

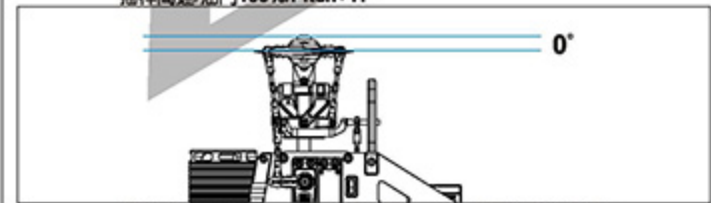

Stick Position at Middle/Throttle 90%/Pitch 0°
搖桿中速/油門90%/Pitch 0°

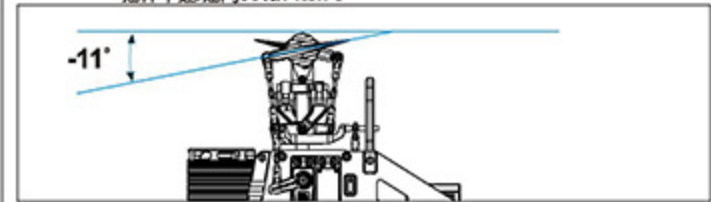

Stick Position at Low/Throttle 100%/Pitch -11°
搖桿低速/油門100%/Pitch -11°



1. Pitch range: Approx. 25 degrees.
 2. If the pitch is set too high, it will result in shorter flight duration and poor motor performance.
 3. Setting the throttle to provide a higher speed is preferable to increasing the pitch too high.
1. 螺距(Pitch)總行程約 25
2. 過大螺距設定，會導致動力與飛行時間降低。
3. 動力提升以較高轉速的設定方式，優於螺距調大的設定。

GENERAL FLIGHT 一般飛行模式

Throttle 油門	Pitch 螺距
5 100% High Speed 100% 高速	+9~+11°
4 85%	
3 65~70% Hovering 65~70% 停懸	+5°
2 40%	
1 0% Low Speed 0% 低速	-2~0°

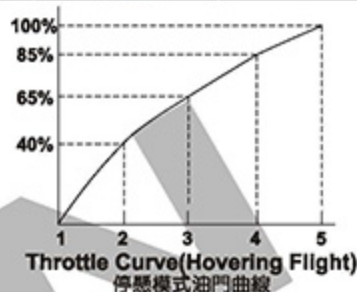

IDLE 1 : SPORT FLIGHT

Throttle 油門	Pitch 螺距
5 90%	+11°
4 85%	
3 80%	+5°
2 85%	
1 90%	-5°

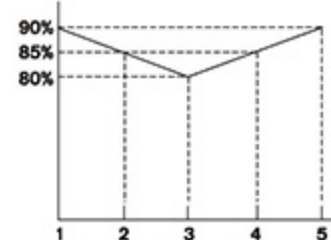

Throttle Curve (Simple Aerobatic Flight)
空中飛行模式油門曲線

IDLE 2 : 3D FLIGHT

Throttle 油門	Pitch 螺距
5 90% High 90% 高	+11°
3 85% Middle 85% 中	0°
1 90% Low 90% 低	-11°

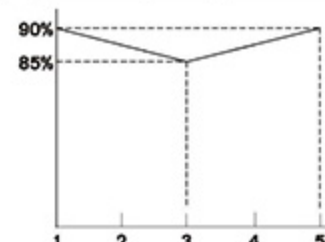

While pitch set at 0 degree, make sure to set throttle below 85%.
螺距0度點，油門勿超過85%。

RCM-BL520MX MOTOR 無刷馬達

This new Brushless motor developed by the ALIGN POWER R&D TEAM, is packed with the latest, cutting edge technology available today. It features exceptional levels of high-torque power. The 520MX utilizes an 6-pole outrunner stator-rotor and unrivaled Ndfeb extra strong magnets that traditional magnets cannot compare to. Also included is a high temperature, wear-resisting, low friction, double ZZ high efficiency bearing. The 520MX will be the most revolutionary motor operating on low current amperage, and delivering high torque to RC models.

由亞拓動力團隊獨家研發出新款的無刷馬達，具有超高扭力特色，採用9槽矽鋼片、6極外轉子以及傳統磁鐵無法比擬的釹鐵錳超強磁鐵，搭配高溫耐磨的雙ZZ超高效率精密軸承設計，電流低、扭力強，將是下一波動力革命中的最具代表性的一顆星。

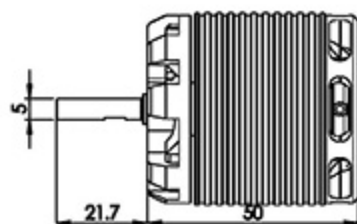

(Unit單位:mm)

SPECIFICATION 尺寸規格

KV	KV值	1600KV(RPM/V)	Input Voltage	輸入電壓	6S
Stator Diameter	定子外徑	35 mm	Stator Thickness	定子高度	27mm
Stator Arms	矽鋼片槽數	9	Magnet Poles	磁鐵極數	6
Max Continuous Current	最大持續電流	85A	Max Instantaneous Current	最大瞬間電流	130A(2sec)
Max Continuous Power	最大持續功率	1900W	Max Instantaneous Power	最大瞬間功率	2750W(2sec)
Dimension	尺寸	Shaft 軸 ϕ 5x45x71.7mm	Weight	重量	Approx. 267g

RCE-BL80A BRUSHLESS SPEED CONTROLLER INSTRUCTION MANUAL

PRODUCT FEATURES 產品特色



RCE-BL80A Brushless ESC can be set up by ALIGN ASBOX Multifunction Programmer. So please scan QR code for ALIGN website start downloading for more information: <http://www.align.com.tw/download-en/asbox/>

RCE-BL80A無刷調速器可透過ALIGN ASBOX 多功能設定盒進入參數設定，請掃描QR Code 連結亞拓網站下載相關資訊：
<http://www.align.com.tw/download-en/asbox/>

- High performance microprocessor for excellent motor speed-governing and super soft start-up.
- Microprocessor powered by independent DC regulator has better anti-interference performance, which greatly reduces the risk of losing control.
- DEO (Driving Efficiency Optimization) Technology adopted greatly improves throttle response & driving efficiency, reduces ESC temperature.
- New switch-mode BEC with adjustable output voltage ranges from 5V to 8V and continuous/peak current of 10A/25A.
- BEC is separated from other circuits of the ESC, it may keep normal output even when MOSFET board of the ESC is burnt or breakdown.
- Multiple flight modes: Fixed-wing, Helicopter (Linear Throttle), Helicopter (Elf Governor), Helicopter (Store Governor).
- New governor program with adjustable governor parameter P/I brings excellent speed-governing function, keep the propeller revs stability when the load changes dramatically.
- Data logging records the standardized RPM, minimum voltage and maximum temperature of the flight.
- "Auto restart function" can manually interrupt the auto rotation and quickly restart the motor to avoid crashes caused by incorrect operations.
- Independent output port for RPM (that is: motor speed) signals. • Separate programming port for ESC parameter setup through ALIGN ASBOX Multifunction Programmer.
- WIFI module for programming the ESC wirelessly with your smart phone (IOS or Android).
- Allow for data checking, ESC programming, speed curve checking, and firmware upgrade online. (ALIGN ASBOX Multifunction Programmer or WIFI Express is needed)
- Multiple protections like start-up protection, ESC thermal protection, capacitor thermal protection, over-current protection, overload protection, and throttle signal loss protection.
- 使用高性能微處理器，相容多種無刷馬達，具備優異的定速和緩啟動性能。
- 微處理器採用獨立的穩壓IC給供電，具有更好的抗干擾能力，降低失控的可能性。
- 採用同步整流驅動效率優化技術 (DEO, Driving Efficiency Optimization)，油門回應更快，驅動效率更高，電子調速器溫度更低。
- 使用新的大功率開關穩壓BEC，輸出電壓在5-8V之間可調，瞬間輸出電流提升至25A。
- BEC模組和電子調速器其他電路相互獨立，當電子調速器功率板出現燒毀等故障時，最大限度保證BEC正常輸出，提供救機機會。
- 具有“固定翼模式/直升機線性油門模式/直升機定速模式/直升機存儲定速模式”4種飛行模式。
- 使用新的直升機定速程式，定速感度可調，易於操作；具有優異的定速效果，在負荷急劇變化的情況下，保證螺旋槳轉速穩定。
- 具有飛行資料記錄功能，可記錄當次飛行的最低電壓、最高溫度資料、最大電流、標定轉速。
- 具有熄火降落保護功能，在保護時間內可手動中斷熄火降落過程並快速重新啟動馬達，避免因失控而墜機。
- 具有轉速 (RPM) 訊號輸出介面。
- 具備獨立參數設定介面，用於連接多功能LCD專業程式設計ALIGN ASBOX 多功能設定盒進行參數設定。
- 支援WIFI無線設定，通過手機端 (蘋果&安卓) 軟體可完成所有參數設置 (需要WIFI模組)。
- 支援線上讀取、設定電壓參數，查看速度曲線表 (存儲模式下)，升級電子調速器固件 (需要ALIGN ASBOX多功能設定盒或WIFI模組)。
- 具有啟動保護、溫度保護、電容溫度保護、電流保護、過負荷保護、油門信號丟失保護、輸入電壓異常保護多重保護功能，有效延長電調使用壽命。

SPECIFICATIONS 產品規格

Model 型號	Main Applications 應用範圍	Input Voltage 輸入電壓	Cont./Peak Current (10s) 持續/瞬間 (10秒) 電流	BEC Voltage BEC 電壓
RCE-BL80A Brushless ESC	For 450-500 Class Helicopter (Propeller: 380~470mm) 450-500級電動直升機 (槳長: 380~470mm)	3~6S LiPo Battery/11.1V~22.2V 3~6S鋰電池/11.1V~22.2V	80A/100A	Switch-mode, 5V~8V Adjustable Voltage (Step: 0.1V), 10A/25A Cont./Peak Current 開關電壓BEC, 輸出電壓5V~8V可調(調 整幅度為0.1V每階), 輸出電流持續 10A, 瞬間25A
	Throttle Signal/BEC Output Wire/RPM Signal Transmission Wire 油門信號/BEC輸出線/RPM信號傳輸線		Size/Weight 尺寸/重量	Separate Programming Port 獨立參數程式設計介面
	White/Red/Black: Throttle Signal Wire ; Red/Brown: BEC Output Wire ; Yellow: RPM Signal Transmission Wire 白、紅、黑三色線為油門信號線; 紅、棕二色線為BEC輸出 線; 黃色為RPM信號傳輸線	70x38.2x20.4mm / 97g	For connecting ALIGN ASBOX Multifunction Programmer, WIFI module. 用於連接ALIGN ASBOX多功能設定盒或 WIFI模組	

USER GUIDE 使用說明書



The default throttle range of this ESC is from 1100 μ s to 1940 μ s, so you need to re-calibrate the throttle range when the first time you use this ESC or after you replace the transmitter.

電子調速器的油門行程出廠預設值為1100 μ s~1940 μ s, 當首次使用電子調速器或者更換其他遙控器使用時, 均應重新設定油門行程。

I. Connections 接線示意圖

- A RPM Signal Wire (Yellow):** plug it into the RPM input channel on the flybarless system. (This wire can be used for provide RPM signal data when using external speed-governing device.)
- B BEC Output Wire (Red/Brown):** plug it into the battery channel or any unoccupied channel on the receiver. (For better BEC power supply, we recommend plugging this wire into the battery channel or any unoccupied channel on FBL system if the FBL system is permitted.)
- C Throttle Signal Wire (White/Red/Black):** plug it into the throttle channel on the receiver or the corresponding channel on the FBL system, For which channel you should plug it in, it depends on what kind of receiver and FBL system you use. The White wire is for transmitting throttle signals, the Red & Black cables are parallelly connected in the BEC output wire, which means BEC voltage output wire and ground cable.

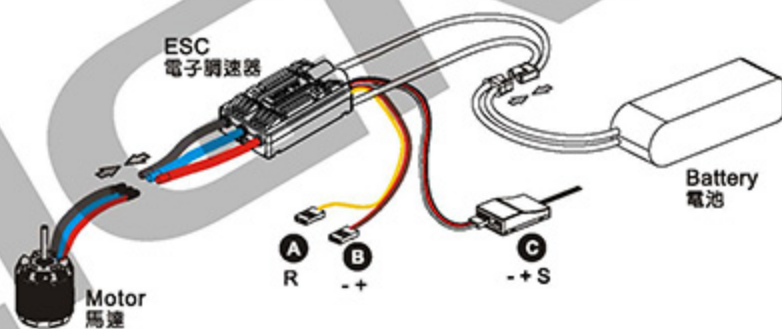

- A RPM信號線(黃):** 插入無平衡翼系統轉速輸入通道; (當使用外部定速時, 可使用RPM信號線提供轉速信號輸入。)
- B BEC輸出線(紅、棕):** 這條額外的BEC輸出線插入接收機電池專用通道或任意空閒通道。(為獲得更好的BEC供電效果, 在無平衡翼系統允許的情況下, 建議將BEC線插入無平衡翼系統的電池專用通道或任意空閒通道。)
- C 油門信號線(白、紅、黑):** 插入接收機油門通道或無平衡翼系統對應通道, 具體視接收機類型及無副翼系統類型而定。其中白線用於傳送油門信號, 而紅線和黑線分別並聯在內部BEC的輸出端(即BEC電壓輸出線和地線)。

The motor rotates in different direction with different brand ESCs. If the wrong rotating direction happens, please switch any two cables to make the motor rotates in right direction.

由於各品牌電子變速器的馬達啟動轉向不盡相同, 若發生轉向錯誤時, 請將馬達與電子變速器的接線任兩條對調即可。

II. Throttle Range Calibration 油門行程校準操作方法



During the ESC/Radio calibration, please set the throttle curve to NORMAL and ensure the corresponding throttle amounts to the maximum throttle endpoint and the minimum throttle endpoint on your transmitter are respectively 100% and 0%.

進行油門行程校準時, 請將油門曲線設置為NORMAL, 並確保遙控器油門最高點對應的油門值為100%, 油門最低點對應的油門值為0%。

- Turn on the transmitter and move the throttle stick to the top position.
開啟遙控器, 將油門打到最高點
- Connect the ESC to a battery. The motor will emit "123" indicating the ESC is powered on normally.
電子調速器接電池, 馬達鳴叫"123"提示音, 表示供電正常
- 5 seconds later, the motor will emit two short beeps indicating the maximum throttle position has been successfully calibrated and accepted.
等待5秒, 馬達發出"嗶-嗶"雙短鳴音, 表示油門最高點校準成功
- Move the throttle stick to the bottom position. 1 second later, a short beep will emit indicating the minimum throttle position has been accepted.
將油門搖杆推到最低, 等待1秒, 油門最低點校準成功
- The ESC will keep beeping indicating the number of LiPo cells you have plugged in.
馬達發出N聲鳴音, 表示鋰電池Cell數
- A long beep represents system is well done, ready to fly.
馬達發出"嗶"一聲長音表示系統準備就緒, 可隨時起飛

PLEASE PRACTICE SIMULATION FLIGHT BEFORE REAL FLYING 飛行前請先熟練電腦模擬飛行

A safe and effective practice method is to use the transmitter flying on the computer through simulator software sold on the market. Do a simulation flight until you familiarize your fingers with the movements of the rudders, and keep practicing until the fingers move naturally.

1. Place the helicopter in a clear open field (Make sure the power OFF) and the tail of helicopter point to yourself.

2. Practice to operate the throttle stick (as below illustration) and repeat practicing "Throttle high/low", "Aileron left/right", "Rudder left/right", and "Elevator up/down".

3. The simulation flight practice is very important, please keep practicing until the fingers move naturally when you hear operation orders being call out.

在還沒瞭解直昇機各動作的操控方式前，嚴禁實機飛行，請先進行電腦模擬飛行的練習，一種最有效、最安全的練習方式，就是透過市面販售的模擬軟體，以遙控器在電腦上模擬飛行，熟悉各種方向的操控，並不斷的重複，直到手指可熟練的控制各個動作及方向。

1. 將直昇機放在空曠的地方(確認電源為關閉)，並將直昇機的機尾對準自己。

2. 練習操作遙控器的各搖桿(各動作的操作方式如下圖)，並反覆練習油門高/低、副翼左/右、升降舵前/後及方向舵左/右操作方式。

3. 模擬飛行的練習相當重要，請重複練習直到不需思索，手指能自然隨著喊出的指令移動控制。



Mode 1	Mode 2	Illustration 圖示
		<p>Move Left 左移</p> <p>Rotate Left 左翻</p> <p>Move Right 右移</p> <p>Rotate Right 右翻</p>
		<p>Fly Forward 前進</p> <p>Forward Rotate 前翻</p> <p>Fly Backward 後退</p> <p>Backward Rotate 後翻</p>
		<p>Ascent 上升</p> <p>Descent 下降</p>
		<p>Turn Right 右旋</p> <p>Turn Left 左旋</p>

FLIGHT ADJUSTMENT AND NOTICE 飛行調整與注意



注意

- Check if the screws are firmly tightened.
- Check if the transmitter and receivers are fully charged.
- 再次確認→螺絲是否鎖固?
- 發射器和接收器電池是否足夠。



注意

If there are other radio control aircraft at the field, make sure to check their frequencies and tell them what frequency you are using. Frequency interference can cause your model, or other models to crash and increase the risk of danger. 假使飛行場有其他遙控飛機，請確認他們的頻率，並告知他們您正在使用的頻率，相同的頻率會造成干擾導致失控和大大地增加風險。

- When arriving at the flying field.
- 當抵達飛行場



STARTING AND STOPPING THE MOTOR 啟動和停止馬達



注意

First check to make sure no one else is operating on the same frequency. Then place the throttle stick at lowest position and turn on the transmitter.

首先確認附近沒有其他相同頻率的的使用，然後打開發射器將油門搖桿推到低點。

- Check the movement.
- 動作確認



ONI Step1
First turn on the transmitter.
先開啟發射器



ONI Step2
Connect to the helicopter power
接上直昇機電源



注意

Check if the throttle stick is set at the lowest position.

確認油門搖桿是在最低的位置。

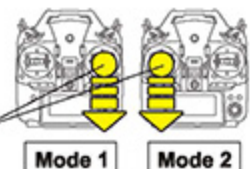

- Are the rudders moving according to the controls?
- Follow the transmitter's instruction manual to do a range test.
- 方向舵是否隨著控制方向移動?
- 根據發射器說明書進行距離測試。



OFF! Step3
Reverse the above orders to turn off.
關閉電源時請依上述操作動作反執行。

This procedure is best performed on soft surfaces such as grass. The use of rubber skid stopper is recommended on hard surface to prevent vibration feedback from the ground to Gyro, resulting in over-corrections.

將直升機置於柔軟地面上，建議硬地起飛腳架裝上避震墊圈。避免升空前腳架與過硬的地面震動太大反饋至機身上的陀螺儀，影響無平衡系統升空前過度修正。

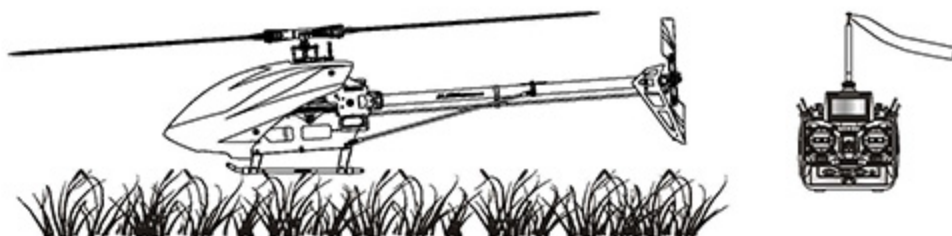

If swashplate should tilt prior to lift off, do not try to manually trim the swashplate level. This is due to vibration feedback to the Gyro, and will disappear once helicopter lifts off the ground. If manual trim is applied, helicopter will tilt immediately after liftoff.

直昇機離地前，十字盤可能因陀螺儀受震動的回饋，使十字盤有傾斜的情形，此時請勿刻意將十字盤修正為水平狀態，此現象只要離地升空時立即解除，可平穩升空；若刻意將十字盤修正為水平時，反而會造成感應器過度修正，一離地即偏向修正方向的危險。

MAIN ROTOR ADJUSTMENTS 主旋翼雙槳平衡調整

1. Before adjusting, apply a red piece of tape on one blade, or paint a red stripe with a marker or paint to identify on blade.
2. Raise the throttle stick slowly and stop just before the helicopter lifts-off ground. Look at the spinning blades from the side of the helicopter.
3. Look at the path of the rotor carefully. If the two blades rotate in the same path, it does not need to adjustment. If one blade is higher or lower than the other blade, adjust the tracking immediately.

1. 調整前先在其中一支主旋翼的翼端，貼上有顏色的貼紙或畫上顏色記號，方便雙槳調整辨識。
2. 慢慢的推起油門搖桿到高點並且停止，在飛機離地前，從飛機側邊觀察主旋翼轉動。
3. 仔細觀察旋翼軌跡(假如兩支旋翼移動都是相同軌跡，則不需要調整；可是如果一支旋翼較高或較低產生“雙槳”的情形時，則必須立刻調整軌跡)。

- a. When rotating, the blade with higher path means the pitch is too big. Please shorten ball link for regular trim.
- b. When rotating, the blade with lower path means the pitch is too small. Please lengthen ball link for regular trim.

- a. 旋翼轉動時較高軌跡的主旋翼表示螺距(PITCH)過大，請調短連桿修正。
- b. 旋翼轉動時較低軌跡的主旋翼表示螺距(PITCH)過小，請調長連桿修正。



Tracking adjustment is very dangerous, so please keep away from the helicopter at a distance of at least 10m.

調整軌跡非常危險，請於距離飛機最少10公尺的距離。

Incorrect tracking may cause vibrations. Please repeat adjusting the tracking to make sure the rotor is correctly aligned. After tracking adjustment, please check the pitch angle is approx. $+5\sim 6^\circ$ when hovering.

不正確的旋翼軌跡會導致震動，請不斷重複調整軌跡，使旋翼軌跡精準正確。在調整軌跡後，確認一下Pitch角度在停旋時應為大約 $+5\sim 6^\circ$ 。

Color Mark 有標示記號的主旋翼



FLIGHT ADJUSTMENT AND NOTICE 飛行調整與注意



- ⊙ Do not attempt to grab or make contact with the helicopter while the main blades are in motion and keep your eyes away from the helicopter. During take-off, landing, and flight, be sure to keep the helicopter away from all obstacles. Operators must stand at least 10 meters away from the helicopter to avoid injury caused by loose parts due to improper assembly or any unforeseen dangers.

- ⊙ 嚴禁用手抓取運行中的直昇機，並禁止將直昇機對著眼睛，當主旋翼轉動後，或起飛/試飛時，務必遠離障礙物，站立位置必需距離10公尺以上，避免因人為組裝不當造成零件脫落，而引發不可預期的財物及人員損傷。



- ⊙ Make sure that no one or obstructions in the vicinity.
- ⊙ For flying safety, please carefully check if every movement and directions are correct when hovering.
- ⊙ 確認鄰近地區沒有人和障礙物。
- ⊙ 為了飛行安全，您必須先確認停懸時各項操控動作是否正常。



Do not attempt to fly until you have some experiences with the operation of helicopter.
嚴禁無熟練操控飛行經驗者操控飛行。

STEP 1 THROTTLE CONTROL PRACTICE 油門控制練習

◎When the helicopter begins to lift-off the ground, slowly reduce the throttle to bring the helicopter back down. Keep practicing this action until you control the throttle smoothly.

◎當直昇機開始離地時，慢慢降低油門將飛機降下。持續練習飛機從地面上升和下降直到您覺得油門控制很順。

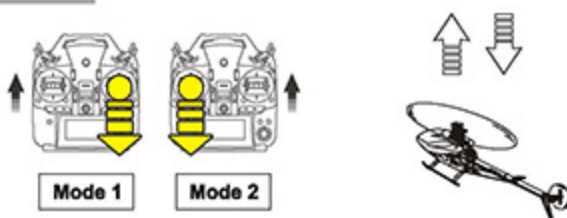

STEP 2 AILERON AND ELEVATOR CONTROL PRACTICE 副翼和升降控制練習

1. Raise the throttle stick slowly.
2. Move the helicopter in any direction back, forward, left and right, slowly move the aileron and elevator sticks in the opposite direction to fly back to its original position.

1. 慢慢升起油門搖桿。
2. 使直昇機依指示：移動向後/向前/向左/向右，慢慢的反向移動副翼和升降搖桿並將直昇機回到原來位置。

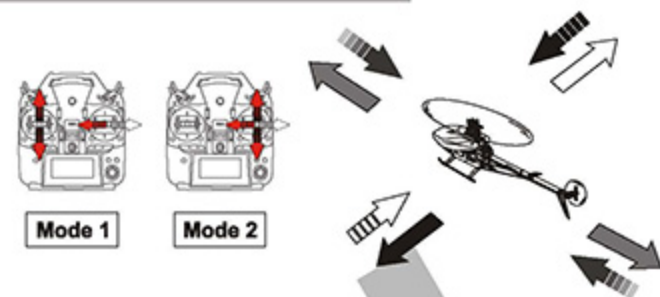

◎If the nose of the helicopter moves, please lower the throttle stick and land the helicopter. Then move your position diagonally behind the helicopter 10M and continue practicing.

◎If the helicopter flies too far away from you, please land the helicopter and move your position behind 10M and continue practicing.

◎當直昇機機頭偏移時，請降低油門並且降落，然後移動自己的位置到直昇機的正後方10公尺再繼續練習。

◎假如直昇機飛離你太遠，請先降落直昇機，並到直昇機後10公尺再繼續練習。

STEP 3 RUDDER CONTROL PRACTICING 方向舵操作練習

1. Slowly raise the throttle stick.
2. Move the nose of the helicopter to right or left, and then slowly move the rudder stick in the opposite direction to fly back to its original position.

1. 慢慢升起油門搖桿。
2. 將直昇機機頭移動左或右，然後慢慢反向移動方向舵搖桿並將直昇機飛回原本位置。

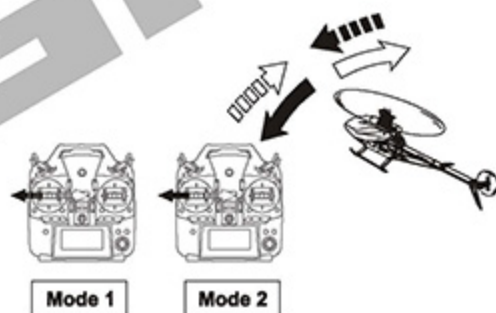

STEP 4

After you are familiar with all actions from STEP1 to 3, draw a circle on the ground and practice within the circle to increase your accuracy.

當你覺得 STEP1~3 動作熟悉了，在地上畫圓圈並在這個圓圈的範圍內練習飛行，以增加你操控的準確度。

◎You can draw a smaller circle when you get more familiar with the actions.

◎當你更加習慣操作動作，你可以畫更小的圓圈。

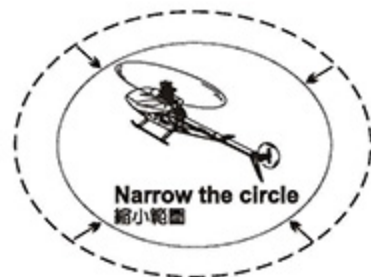

STEP 5 DIRECTION CHANGE AND HOVERING PRACTICE 改變直昇機方向和練習停旋

After you are familiar with STEP1 to 4, stand at side of the helicopter and continue practicing STEP1 to 4. Then repeat the STEP1 to 4 by standing right in front of the helicopter.

當你覺得STEP1~4動作熟悉了，站在面對直昇機側邊並繼續練習STEP1~4。之後，站在直昇機機頭右邊重複步驟練習。

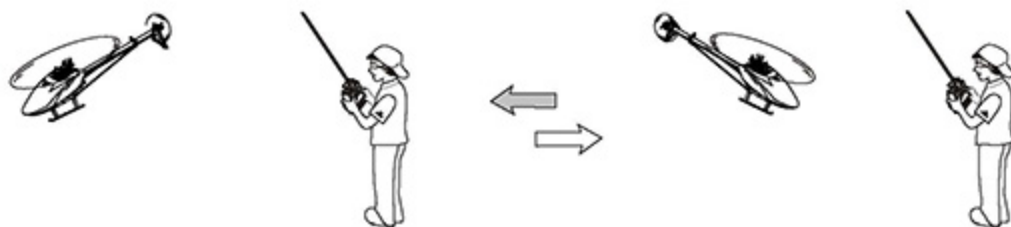

	Problem 狀況	Cause 原因	Solution 對策
Blade Tracking 雙槳平衡	Tracking is Off 雙槳	Pitch linkage rods are not even length PITCH連桿長度調整不平均	Adjust length of ball link. 調整連桿頭長度
Hover 停懸	Head speed too low 主旋翼轉速偏低	Excessive pitch 主旋翼的PITCH偏高	Adjust ball link to reduce pitch by 4 to 5 degrees. 調整連桿頭調低Pitch約+4~5度
		Hovering throttle curve is too low 停懸點油門曲線過低	Increase throttle curve at hovering point on transmitter (around 60%) 調高停懸點油門曲線(約60%)
	Head speed too high 主旋翼轉速偏高	Not enough pitch 主旋翼的PITCH偏低	Adjust ball link to increase pitch by 4 to 5 degrees. 調整連桿頭調高Pitch約+4~5度
		Hovering throttle curve is too high 停懸點油門曲線過高	Decrease throttle curve at hovering point on transmitter (around 60%) 調低停懸點油門曲線(約60%)
Rudder Response 尾舵反應	Drifting of tail occurs during hovering, or delay of rudder response when centering rudder stick. 停懸時尾翼向某一邊偏移，或撥動方向舵並回復到中立點時，尾翼產生延遲，無法停頓在所控制位置上。	Rudder neutral point improperly set 尾中立點設定不當	Reset rudder neutral point 重設尾中立點
	Tail oscillates (hunting, or wags) at hover or full throttle 停懸或全油門時尾翼左右來回搖擺。	Rudder gyro gain too low 尾舵陀螺儀敏感度偏低	Increase rudder gyro gain 增加尾舵陀螺儀敏感度
		Rudder gyro gain too high 尾舵陀螺儀敏感度偏高	Reduce rudder gyro gain 降低尾舵陀螺儀敏感度

If above solution does not resolve your issues, please check with experienced pilots or contact your Align dealer.

※在做完以上調整後，仍然無法改善情況時，應立即停止飛行並向有經驗的飛手諮詢或連絡您的經銷商。

Thank you for purchasing and supporting ALIGN products.

The Align Team is dedicated to you by innovating and developing new RC Helicopters, Multicopters, and FPV Racing Quads. We strive to provide a more diversified experience for our customers. Visit our website at www.align.com.tw for latest news, information, and updates about our extensive line of products for the RC enthusiasts.

Good Flying!

再次感謝您對亞拓系列商品的喜愛與支持，您的肯定是對我們最大的認同。

亞拓團隊秉持創新研發的精神，開發遙控直昇機／多軸飛行機／穿越機系列商品，提供給您體驗更多樣化的飛行樂趣。您可以透過下列連結，隨時瞭解亞拓的最新動態，以及各項訊息分享。

祝福您有一個愉快的飛行體驗。



ALIGN Flight Safety 亞拓飛行安全宣導

<http://www.align.com.tw/flysafe-en/>



ALIGN T-REX Helicopter 亞拓遙控直昇機

<http://www.align.com.tw/helicopter-en/>



ALIGN Multicopter 亞拓多軸飛行機

<http://www.align.com.tw/multicopter-en/>



ALIGN FPV Racing Quad 亞拓穿越機

<http://www.align.com.tw/multicopter-en/mr25/>



ALIGN Website 亞拓官網

<http://www.align.com.tw>



ALIGN Shopping Cart 亞拓購物車

<http://shop.align.com.tw/index.php?language=en>



ALIGN Quick Finder 亞拓零件快速購

<http://shop.align.com.tw/partfinder.php?language=en>



ALIGN FaceBook

<https://www.facebook.com/Align-Corporation-194493419543/?ref=mf>



ALIGN Instagram

<https://instagram.com/aligncorporation/>



ALIGN YouTube

https://www.youtube.com/channel/UCaPj_K5DNo7HSmP1eytUvMQ



ALIGN Youku

<http://i.youku.com/u/UMTQ0NjEwNjczNg==>



ALIGN

ALIGN

Specifications & Equipment/規格配備:

Length/機身長:935mm

Height/機身高:259mm

Main Blade Length/主旋翼尺寸:470mm

Tail Blade Length/尾旋翼尺寸:69mm

Main Rotor Diameter/主旋翼直徑:1054mm

Tail Rotor Diameter/尾旋翼直徑:219mm

Motor Pinion Gear/馬達齒輪:12T

Main Drive Gear/傳動主齒輪:134T

Autorotation Tail Drive Gear/尾傳動主齒:80T

Tail Drive Gear/尾翼傳動齒:21T

Drive Gear Ratio/齒輪傳動比:11.17:1:3.81

Flying Weight(without battery)/全配重(不含電池): Approx. 1450g

